

Donaldson  
BOFA™

## V 600

Fume Extraction System

## User Manual

Installation, Operation, and Service Information



This manual contains specific precautions related to worker safety. The hazard alert image denotes safety related instructions and warnings in this manual. DO NOT install, operate, or perform maintenance on this system until you have read and understood the instructions, precautions and warnings contained within this manual.

English  
Master Language

UM-V 600-BOFA-US  
Revision 1.0

## Donaldson BOFA Technical Service

If a problem arises with your system, please refer to the troubleshooting section of this manual. If the problem is still not resolved, please:

- Visit our website at [donaldsonbofa.com](http://donaldsonbofa.com) for online help.
- Or contact the helpline:
  - ROW: +44 (0) 1202 699 444 (Mon-Fri 9am-5pm GMT)
  - US: +1 (618) 205 5007 (Mon-Fri 9am-5pm CST).
- Email:
  - ROW: [bofatechnical@donaldson.com](mailto:bofatechnical@donaldson.com)
  - US: [bofatechnicalus@donaldson.com](mailto:bofatechnicalus@donaldson.com)

## Serial Number

For future reference, fill in your system details in the space provided. The serial number is on the rating label located on the side/rear of the system.



## Table of Contents

<b>1</b>	<b>Overview.....</b>	<b>1</b>
1.1.	Front view of V 600	1
1.2.	Rear view of V 600	2
1.3.	Overview of control panel	3
<b>2</b>	<b>Safety information .....</b>	<b>3</b>
2.1.	Important safety notes	3
2.2.	Warning and information labels	4
2.3.	Fire risk warning	5
<b>3</b>	<b>Before installation .....</b>	<b>6</b>
3.1.	Packaging removal and system placement	6
<b>4</b>	<b>Installation .....</b>	<b>7</b>
4.1.	Fume capture methods	7
4.2.	General guidelines for a successful installation	7
4.3.	Flexible arm and nozzle extraction	7
4.4.	Moving products	7
4.5.	Enclosures	7
4.6.	Cabinets	8
4.7.	Connection to extraction system	8
4.8.	Exhausting filtered air outside	8
4.9.	Connection to power supply	8
4.10.	Optional added features	9
4.10.1.	Remote stop/start signal (optional)	9
4.10.2.	DC voltage input (optional)	9
4.10.3.	Override (optional)	9
<b>5</b>	<b>Operation.....</b>	<b>10</b>
5.1.	Turning extraction system on	10
5.2.	Setting the desired airflow	10
5.3.	To set the airflow	10
5.3.1.	Variable airflow speed	10
<b>6</b>	<b>Maintenance .....</b>	<b>11</b>
6.1.	Maintenance UK	11
6.1.1.	Maintenance general	11
6.1.2.	Cleaning the extraction system	11
6.2.	Replacing filters	11
6.2.1.	Pre-filter replacement	12
6.2.2.	Combined filter replacement	12
<b>7</b>	<b>Troubleshooting.....</b>	<b>13</b>
7.1.	Fault indication	13

<b>8</b>	<b>Replacement parts</b> .....	<b>14</b>
8.1.	Consumable spares	14
8.2.	Maintenance protocol	14
8.3.	Filter disposal	14
<b>9</b>	<b>System specifications</b> .....	<b>15</b>
<b>10</b>	<b>Contact information</b> .....	<b>16</b>
<b>11</b>	<b>Inspection record</b> .....	<b>17</b>

# 1 Overview

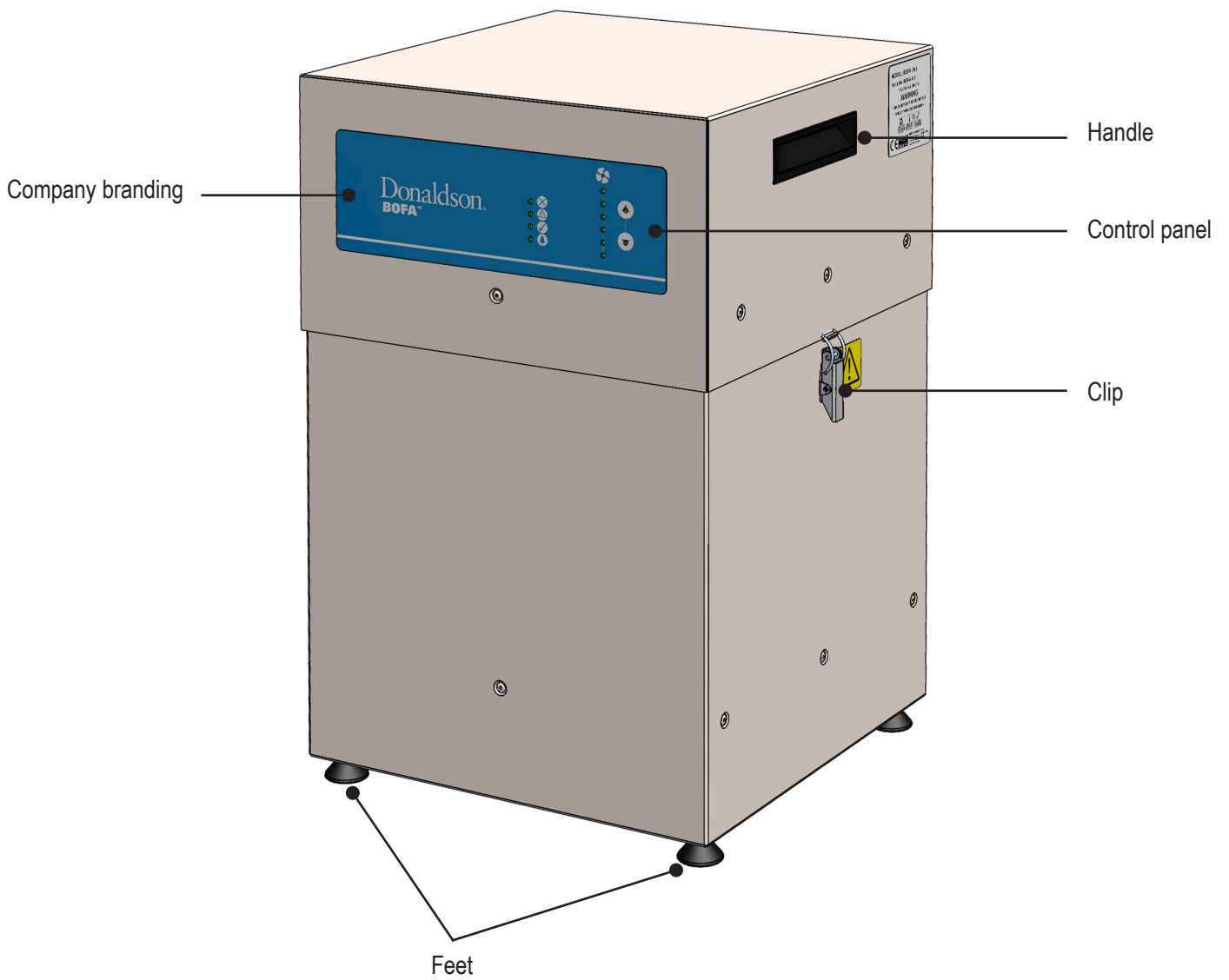
## 1.1 Front view of V 600



1.2. Rear view of V 600

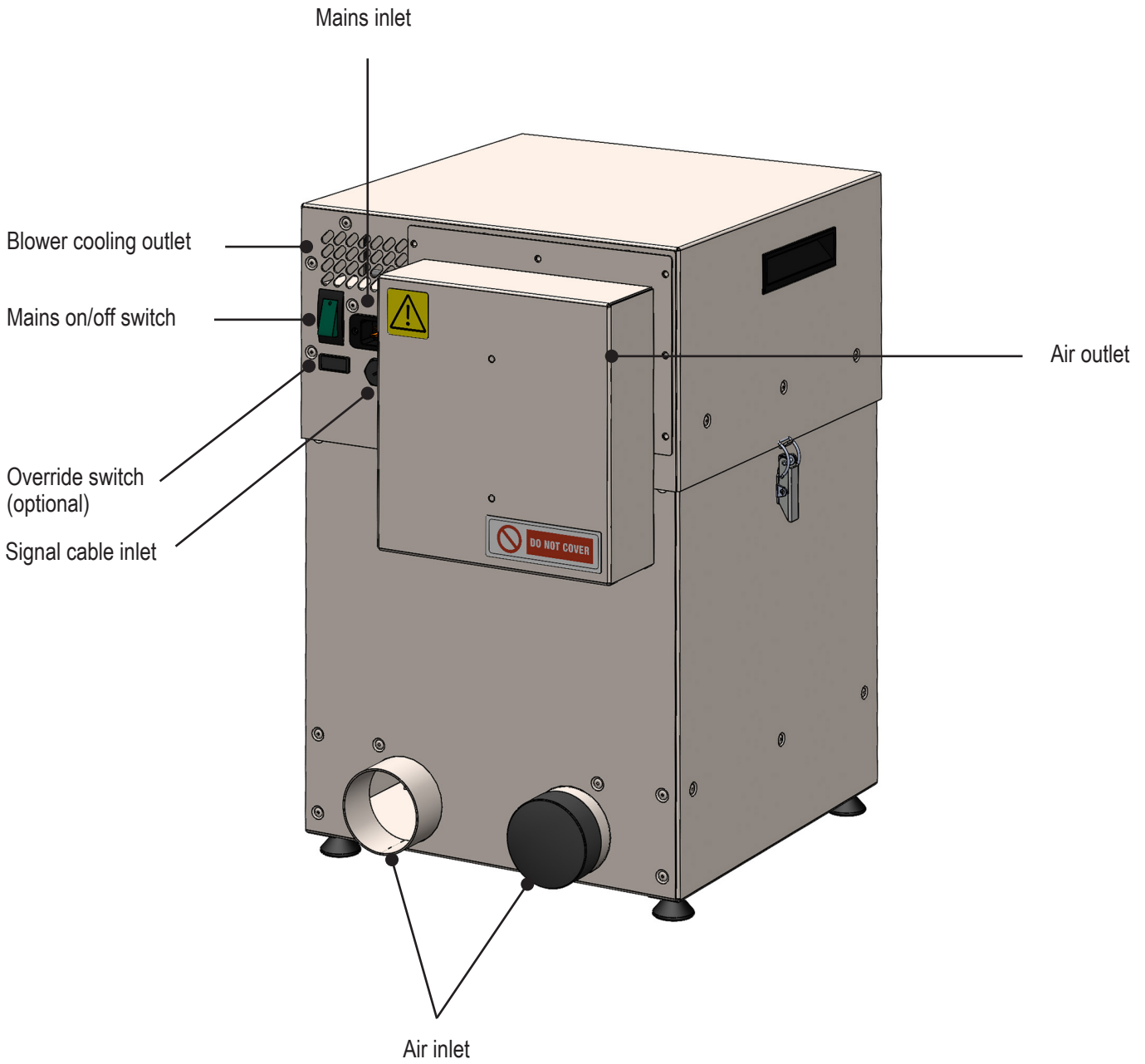

### 1.3. Overview of control panel



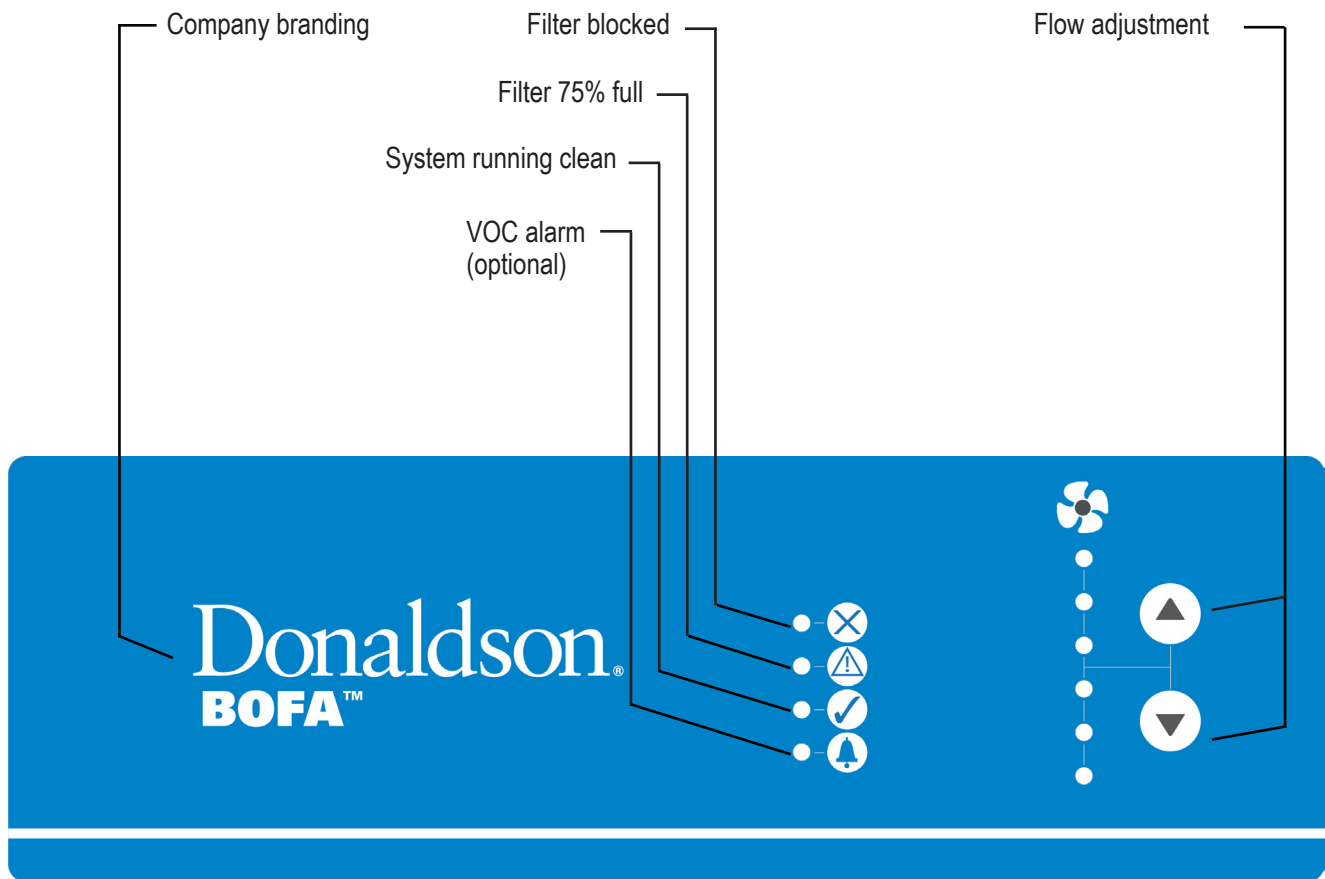

The diagram below shows an overview of the control panel.



## 2 Safety information

### 2.1 Important safety notes

Concerning symbols used on the extraction system and referred to within this manual.

Symbol	Meaning	
	DANGER	Refers to an immediately impending danger. If the danger is not avoided, it could result in death or severe (crippling) injury. Please consult the manual when this symbol is displayed.
	WARNING	Refers to a possibly dangerous situation. If not avoided, it could result in death or severe injury. Please consult the manual when this symbol is displayed.
	CAUTION	Refers to a possibly harmful situation. If not avoided, damage could be caused to the product or something in its environment.
	IMPORTANT (refer to manual)	Refers to handling tip and other particularly useful information. This does not signify a dangerous or harmful situation. Refer to manual when this symbol is displayed.

### EU Declaration

The system has been designed to meet the essential health and safety requirements of the Machinery Directive 2006/42/EC, Low Voltage Directive 2014/35/EC, and the EMC Directive 2014/30/EU. For the full DOC and further information please contact the technical team:

- US: [bofatechnicalus@donaldson.com](mailto:bofatechnicalus@donaldson.com)
- ROW: [bofatechnical@donaldson.com](mailto:bofatechnical@donaldson.com)

### Electrical safety

The system has been designed to meet the essential health and safety requirements of the Low Voltage Directive 2014/35/EC. The requirements of the EMC Directive 2014/30/EU are also met.

### Warning

When working with the blower housing open, live 230/115 volt mains components are accessible. Ensure that the rules and regulations for work on live components are always observed.

### Important

To reduce the risk of fire, electric shock, or injury:

1. Always isolate the system from the mains power supply before removing the blower access panel.
2. Use only as described in this manual.
3. Connect the system to a properly grounded outlet.

## Dangers to eyes, breathing, and skin

Once used, the filters within the extraction system may contain a mixture of particulates, some of which may be sub-micron size. When the used filters are moved, it may agitate some of this particulate, which could get into the breathing zone and eyes of the operative.

Additionally, depending on the materials being processed, the particulate may be an irritant to the skin.

**This system should not be used on processes with sparks of flammable materials or with explosive dusts and gases, without implementation of additional precautions.**

	CAUTION	When changing used filters, always wear a mask, safety shoes, goggles, and gloves.
---	---------	--

## Carbon selection





Please note that the media within the gas filter fitted in the extraction system is capable of adsorbing a wide range of organic compounds. However, it is the responsibility of the user to ensure it is suitable for the particular application it is being used on.

## Intended use

This equipment has been designed to extract and filter fume from a variety of applications. However, it is the user's responsibility to ensure the equipment is installed correctly and is suitable for the application. This extraction system must not be used on wet applications or acidic fumes.

## 2.2. Warning and information labels

The following listing details labels used on your system.

Symbol	Meaning	
	GOGGLES, GLOVES AND MASK	This appears on filters, indicating that goggles, gloves, and masks should be worn while handling used filters.
 	DO NOT COVER	Do not cover any louvers or holes on panels adjacent to the label.
	ELECTRICAL DANGER	Removal of panels with this label attached will allow access to potentially live components.
	WARNING	Power should be isolated before the panel with this label attached is opened/removed.

**PLEASE NOTE:** If the equipment is used in a manner not specified by the manufacturer, the protection provided by the equipment may be compromised.

### 2.3. Fire risk warning

In the very rare event that a burning ember or spark is drawn into the fume extraction system, it may be possible that the filters will ignite. Whilst any resultant fire would typically be retained within the fume extraction system, the damage to the extraction system could be significant.

It is therefore essential to minimize the possibility of this occurring by undertaking an appropriate risk assessment to determine:

- a). Whether additional fire protection equipment should be installed.
- b). Appropriate maintenance procedures to prevent the risk of build-up of debris which could potentially combust.

This extraction system should not be used on processes where sparks could occur, with explosive dusts and gases, or with particulates that can be pyrophoric (can spontaneously ignite), without implementation of additional precautions. It is essential that nozzles or other extraction/fume capture devices and hoses/pipework are cleaned regularly to prevent the build-up of potentially ignitable debris.

## 3 Before installation

### 3.1 Packaging removal and system placement



Before installation, check the extraction system for damage.

All packaging must be removed before the system is connected to the power supply.

**Please read all instructions in this manual before using this extraction system.**

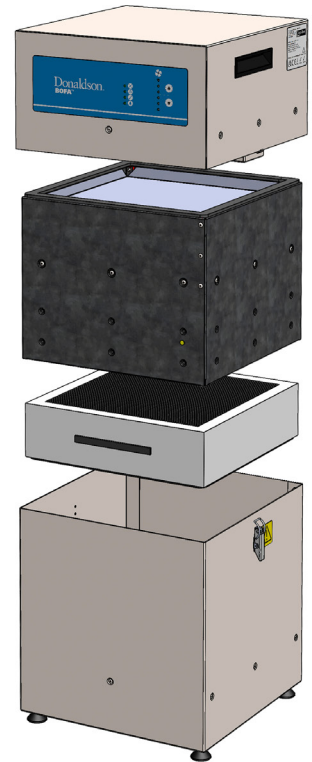
1. Move the system to the location where it is going to be installed and remove the outer packaging.  
**This system should be installed in a well-ventilated area.**
2. Ensure that 20" (500 mm) space is available around any vented panels on the extraction system to ensure adequate airflow.
3. Check the filter is located in its correct position before replacing the lid and securing the clips.



	CAUTION	Due to the weight of the extraction system, suitable lifting equipment should be used and appropriate safety precautions taken (see system specification section for product weight detail).
	CAUTION	Do not block or cover the cooling vents on the extraction system as this severely restricts airflow and may cause damage to the system.
	CAUTION	Under no circumstances should the exhaust outlet/s be covered as this will restrict the airflow and cause overheating.

## 4 Installation

The system has been designed to remove and filter fume containing potentially hazardous particulate generated during manufacturing processes. Such hazardous substances are captured within the filtration system after which the cleaned air is returned to the workplace.

### 4.1. Fume capture methods

The fume is normally captured by 1 of 3 methods.

- Flexible arm/nozzle
- Enclosures
- Cabinets

### 4.2. General guidelines for a successful installation

Laser marking/coding used as an example in the following sections and images.

- Keep duct run length to a minimum.
- Avoid sharp bends/turns in the ductwork.
- Avoid multiple bends/turns in the ductwork.
- Use a larger diameter duct where able.
- Position the capture device as close as possible to the marking point (if used on high-speed lines, position the capture device slightly downstream).

### 4.3. Flexible arm and nozzle extraction

- Stay put arm should be mounted as close as possible to the marking point using the clips provided.
- Unscrew the push-fit connector from the other side of the flexible hose.
- Cut the flexible hose to suit the distance back to the extraction system connection and push onto the system inlet.

Purge air should be kept to a minimum, where possible, to prevent the fume being blown away from the nozzle. High-speed lines may need bigger scoops or nozzles both sides of the product because of the turbulence caused by the speed of the product (e.g., bottling lines).

### 4.4. Moving products

For applications where the product is moving past the stationary marking point head, the capture nozzle should be positioned as close as possible to the marking area on the side the product is moving towards.

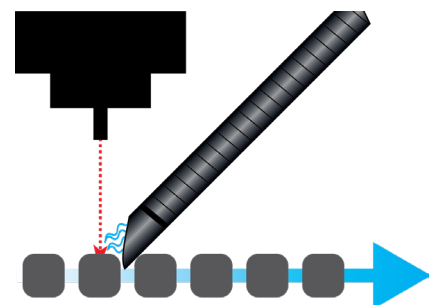

### 4.5. Enclosures

The extraction hose and nozzle can be attached to the enclosure surrounding the marking zone provided that the extraction point is within 1.96"-2.95" (50-75 mm) of the marking point.

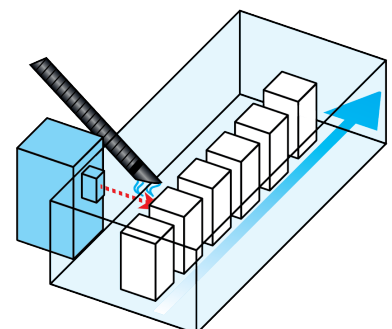

#### 4.6. Cabinets

Cabinets normally have a 2.95" (75 mm) or 3.93" (100 mm) spigot for fume extraction. For best performance, use the same diameter hose as the spigot and reduce at the extraction system end if necessary. **Keep the hose run as short as possible.**

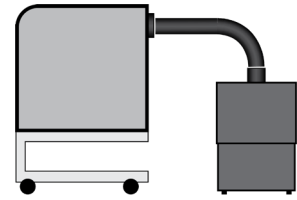

#### 4.7. Connection to extraction system

All ductwork should be installed and connected to the extraction system before it is turned on.

#### 4.8. Exhausting filtered air outside

If requested, your system will have been fitted with an exhaust outlet spigot. This provides a connection point for exhaust pipework to be fitted. It is important to keep any ducting to a minimum to reduce back pressure within the system.

#### 4.9. Connection to power supply

Please follow the specification at the rear of the manual when selecting the power supply outlet for the system. Ensure the power supply is suitable before connecting the system.

	<p><b>ELECTRICAL DANGER</b></p>	<p>Check the integrity of the electrical power cable. If the supply cord is damaged, the extraction system should not be connected to the mains. The supply cord should only be replaced by a Donaldson BOFA engineer as an electrical safety test may be required after replacement.</p>
	<p><b>CAUTION</b></p>	<p>The system <b>MUST</b> be connected to a properly earthed outlet.</p>

If your system was customized for your order, please read the optional features section before the power connection is made as additional connections may be required before power is connected to the extraction system.

Connect the power cable to an isolated electrical supply.

The mains socket should be installed near the extraction system. It should be easily accessible and able to be switched on/off. The cable run must be arranged to prevent trip hazard.

This equipment shall be mounted in accordance with local regulations.

#### Portable appliance testing guidance

This appliance is a Class I electrical product that requires earth protection. The appliance contains Type 3 SPDs (surge protection devices). During PAT Testing, test voltage L-E and N-E must be limited to 250 VDC to avoid engaging the surge protection.

#### 4.10. Optional added features

The system can be configured to suit customer specification. These optional features would be discussed, arranged, and installed prior to delivery.

**If unsure what features your system is equipped with, please contact the seller with the extraction system serial number (refer to section 2 for location), who will be able to advise what specification has been supplied.**

For other custom filter signal configurations (details of connectors and pin-outs), these will be included in an appendix at the rear of the manual.

##### 4.10.1. Remote stop/start signal (optional)

Enables the extraction system to be remotely turned on/off via an external signal. This feature can be configured in 2 ways:

- DC voltage input – range 12-24 VDC
- Override – stop/start feature switched off

**Note: Care must be taken to ensure that the system is correctly wired in order for the extraction system to function correctly.**

##### 4.10.2. DC voltage input (optional)

This configuration requires the black and red cores of the signal cable (refer to section 1 for location) to be connected to a known and tested DC power supply to start the extraction system.

The operating voltage for this signal is between 12 and 24 VDC. Only voltages within this range should be connected. Voltages connected outside of this range may cause irreversible damage to the internal control PCB.

**Red cable = V+**

**Black cable = V-**

When the extraction system is provided with the correct DC voltage, the blower will start and maintain the set flow rate. When the DC voltage is removed, the blower will slow down and come to a stop.

The extraction system will need to be turned on and be out of standby mode in order for this feature to operate.

##### 4.10.3. Override (optional)

Enables the extraction system to operate fully with or without either DC voltage input or the volt-free input.

The override feature can be toggled on/off by a switch mounted on the internal blower access panel (see picture on the right for switch location).

##### Switch in “on” position

In this position, the extraction system will require a start signal (either voltage input or volt-free, depending on the requested specification) to enable the blower within the system.

##### Switch in “off” position

In this position, the extraction system blower will run without the requirement for an external start signal. This feature is useful for engineers carrying out works/tests on the extraction system without the need for the host machine/auxiliary signal.

The power supply unit which is used to provide the 12-24 VDC stop/start voltage signal must be protected by double insulation from mains voltage.

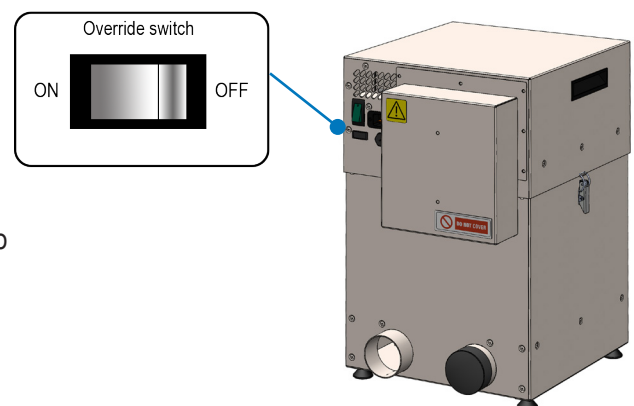

## 5 Operation

### 5.1. Turning extraction system on

The on/off switch must be switched to the “on” position (refer to section 1 for switch location) by depressing the (I) side of the switch.

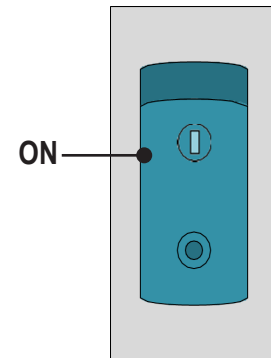

Powder-coated

### 5.2. Setting the desired airflow

The system features variable airflow speed. This enables the user to set the required airflow rate. Over time, as the filters begin to block, the user should manually increase the blower speed to ensure the correct flow is maintained to compensate for any loss in performance caused by the added restriction of the partially blocked filters.



**IMPORTANT**  
(refer to manual)

The extraction system and all pipework must be fully installed and connected before the airflow is set.

### 5.3. To set the airflow

Press the up button to increase airflow and press the down button to decrease airflow. The level of airflow is indicated by the vertical row of six blue LEDs to the right of the mains isolation switch. As the airflow increases, more blue LEDs light up and the opposite for decreasing the airflow.

Increase airflow

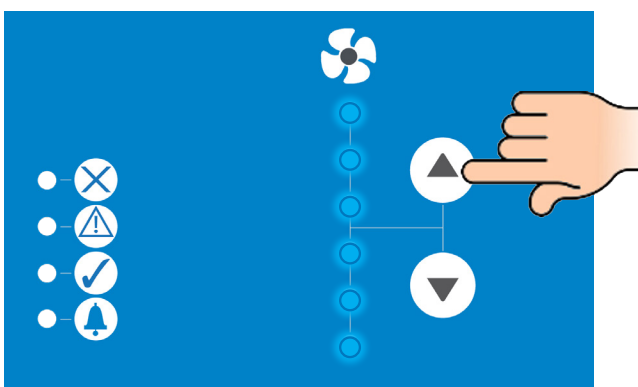

Decrease airflow

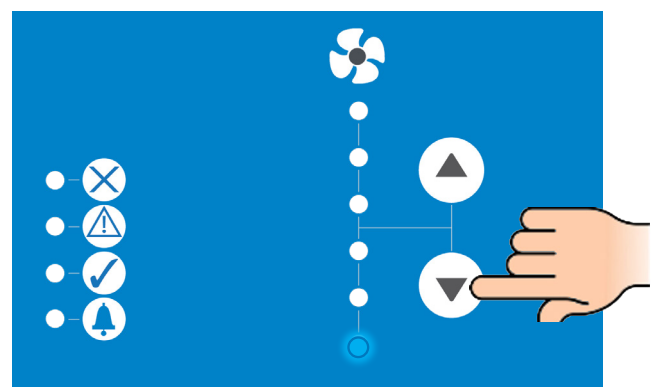

#### 5.3.1. Variable airflow speed

If your extraction system is installed with this optional extra, the airflow can be remotely controlled from a controller run from the system on a signal cable. The airflow is adjusted in the same way as detailed above.

## 6 Maintenance

### 6.1. Maintenance UK

It is a legal requirement, under regulation 9 of the COSHH regulations, that all local exhaust ventilation systems are thoroughly examined and tested at least once every 14 months (typically carried out annually). The approved code of practice recommends that a visual check should be carried out at least once a week.

COSHH requires the annual inspection and testing to be carried out by a competent person and specifies that documentation results are recorded in a log.

Contact the seller for more information about inspection and certification.

#### 6.1.1. Maintenance general

User maintenance is limited to cleaning the system and filter replacement, only the manufacturers trained maintenance technicians are authorized to carry out component testing and replacement. Unauthorized work or the use of unauthorized replacement filters may result in a potentially dangerous situation and/or damage to the extraction system and will invalidate the manufacturer's warranty.

#### 6.1.2. Cleaning the extraction system

The powder-coated finish can be cleaned with a damp cloth and non-aggressive detergent, do not use an abrasive cleaning product as this will damage the finish.

The cooling inlets and outlets should be cleaned once a year to prevent build-up of dust and overheating of the extraction system.

### 6.2. Replacing filters

It is recommended to replace filters every 12 months, unless the system prompts for more frequent changes. Users should maintain a record of these replacements.

It is recommended that a spare set of filters are kept on-site to avoid prolonged extraction system unavailability. Part numbers for replacement filters can be found on the filters fitted in your system.

To prevent overheating, extraction systems should not be run with a blocked filter condition, or with dust obstruction of inlets/outlets.

During use, the extraction system will alert the user when its filter needs replacing. When the filter is 75% full, both the green and amber LEDs will illuminate.



When the filter is full/blocked, the red LED on the control panel will illuminate. All three LEDs will be illuminating as shown below. A filter change is required at this stage.

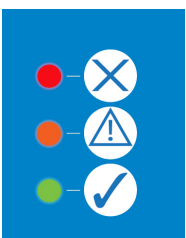

Refer to section 2.2 for PPE requirements.

**Note: The extraction system must not be run if any filter is missing.**

### 6.2.1. Pre-filter replacement

Refer to section 2.2 for PPE requirements.

During use, the system will alert the user when its filter needs replacing. When the filter needs to be changed, the LEDs are illuminated as below.

To remove and replace the pre-filter, follow the procedure detailed below.

1. Isolate the electrical supply to the extraction system.
2. Undo the clips on either side of the system and lift the blower section off.
3. Remove the filters from the base.
4. Vacuum out any dust in the base.
5. Remove the pre-filter from inside the combined filter and replace with a new pre-filter.
6. Locate the combined filter into the base.
7. Replace the blower section and fasten the clips.
8. Reconnect the power supply.



### 6.2.2. Combined filter replacement

To remove and replace the combined filter follow the procedure detailed below.

1. Isolate the electrical supply to the extraction system.
2. Undo the two clips on the sides of the system and remove the blower section using the two handles on the sides of the lid.
3. Lift the filter out of the system. Once removed, it is recommended that the used filters are bagged and sealed.
4. If the current pre-filter is found to be serviceable, place into the new combined filter. Lower the new filter into position.
5. Replace the blower section, and fasten the two clips.
6. Reconnect the power supply.

If the VOC sensor option is installed in your system, the extraction system will monitor and detect the level of VOC particles in the air. If the VOC level rises above a pre-set level then the LED to the left of the bell symbol will illuminate red. This requires the replacement of the combined filter.

**Note:** The system needs to be set at above 75% power for the filter condition LEDs to function.

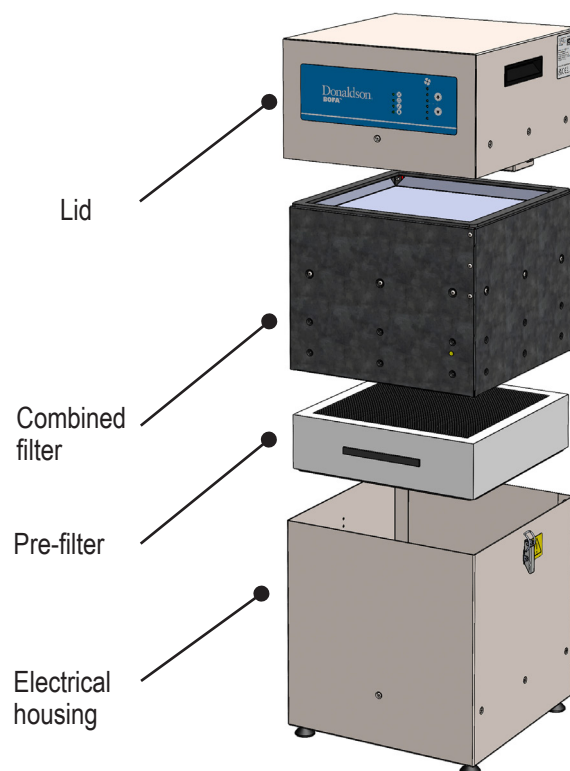

## **7 Troubleshooting**

### **7.1. Fault indication**

In the unlikely event of any other issues with the extraction system, please contact your local representative.



## 9 System specifications

Extraction system: **V 600**

Airflow: 206 cfm (350 m<sup>3</sup>/h)

Weight: 77 lbs (35 kg)

Airflow measuring system: Windvane

Suction pressure: 96 mBar

Blower: Centrifugal fan

Output: 1.1 kW

Noise level: below 60 dB(A) (at typical operating speed)

Maximum altitude: 2000 m

Electrical supply: 115-230 V, 1 ph

Hertz: 50/60 Hz

Full load current: 12.5 A

No. of phases: 1

Indoor use only

Overvoltage category II

Pollution degree 2

Not for use in wet applications

Environmental operating range:

Temperature: +41 °F (5°C) to + 104 °F (40°C)

Humidity: Max 80% RH up to 87.8 °F (31°C)

Max 50% RH at 104 °F (40°C)

Size:

	Imperial (inches)	Metric (mm)
Height	23.2	590
Width	14.7	375
Depth	18.3	465

Filters:

Filter type	Surface area	Efficiency
Pre-filter	62.6 sq ft (5.8 m <sup>2</sup> )	F8 95% @ 0.9 microns
Combined filter	34.8 sq ft (3.2 m <sup>2</sup> )	99.997% @ 0.3 microns

Combined filter (gas section):

Filter type	Carbon type	Volume
Combined filter (gas)	Activated carbon	12.8 ltr

Process fume/gas entering this system should be within the above temperature range.

**Wiring schematic and spare parts list available upon request.**

## 10 Contact information

### Donaldson BOFA head office – UK & ROW:

19-20 Balena Close

Tel. +44 (0) 1202 699 444

Creekmoor Industrial Estate

Email: [bofasales@donaldson.com](mailto:bofasales@donaldson.com)

Poole

Dorset

BH17 7DU

United Kingdom

---

### Donaldson BOFA German office:

Email: [bofavertrieb@donaldson.com](mailto:bofavertrieb@donaldson.com)

---

### Donaldson BOFA US office:

303 S Madison Street

Tel. +1 (618) 205 5007

Stanton, Illinois

Email: [bofasalesus@donaldson.com](mailto:bofasalesus@donaldson.com)

62088 USA

## 11 Inspection record



### Inspection Record

#### Local Exhaust Ventilation System

Health & Safety at Work Act 1974 - Control of Substances Hazardous to Health - Regulation 9 (2002) Thorough Examination and Testing of Local Exhaust Ventilation Systems

Company:	System Designation:	System Installation Date:
Designated Person:		

#### Inspection and Maintenance Schedules

1. Daily checks.
2. Weekly inspection of process enclosure, extract offtake, hose/ducting, and system.
3. Monthly inspection of process enclosure, extract offtake, hose/ducting, and system.
4. Yearly inspection/testing.

**Process enclosure, extract offtake(s), hose/ducting, and system.**

**Inspection and Maintenance Record**

**1. Daily inspection**

Inspection of the process to ensure extract devices/nozzles/enclosures/hoses are in place and correctly positioned. Examination of the system to ensure it is running. This to be carried out by the operator. Daily inspection not recorded.

**2. Weekly inspection**

Weekly inspection by supervisor of physical condition of extract devices/nozzles/enclosures/hoses and system for damage, change (parts added or removed) and correct operation, etc. Check also that daily inspections have been completed. Tick boxes to confirm system ok/change. Add details of any changes.

Report changes to Engineering Manager. Record any remedial actions taken.

Week number	Date	System ok	System change	Details of change/repairs, etc.	Initial
1					
2					
3					
4					
5					
6					
7					
8					
9					
10					
11					
12					
13					
14					
15					
16					
17					
18					
19					
20					
21					
22					
23					
24					
25					

Weekly inspection by supervisor of physical condition of extract devices/nozzles/enclosures/hoses and system for damage, change (parts added or removed) and correct operation, etc. Check also that daily inspections have been completed. Tick boxes to confirm system ok/change. Add details of any changes.

Report changes to Engineering Manager. Record any remedial actions taken.

Week number	Date	System ok	System change	Details of change/repairs, etc.	Initial
26					
27					
28					
29					
30					
31					
32					
33					
34					
35					
36					
37					
38					
39					
40					
41					
42					
43					
44					
45					
46					
47					
48					
49					
50					
51					
52					

**Process enclosure, extract offtake(s), hose/ducting, and system.**

**Inspection and Maintenance Record**

**3. Monthly inspection**

In addition to weekly checks, disconnect hoses and check for blockage and smooth operation of fan, signs of dust or vapor/gas/odor carry over. Tick boxes to confirm system ok/change. Add details of any changes. Report changes to Engineering Manager. Record any remedial actions taken.

Week number	Date	System ok	System change	Details of change/repairs, etc.	Initial
1					
2					
3					
4					
5					
6					
7					
8					
9					
10					
11					
12					

**4. Yearly inspection**

	Comments	Supervisor signature:	Date:
Annual service to include all regular checks, inspection of filter condition, blower, and electrical system, and a filter replacement (if not changed within the previous 12 months).			
Annual thorough inspection and testing of LEV system in accordance with C.O.S.H.H. regulation 9 (max interval 14 months) including reporting.			