

A standalone dust extraction system.

The DustPRO Universal is an industrial standalone extraction system designed to filter swarf and smaller particulates generated from a variety of industrial applications. It features a large 18-liter capacity filter bag and a brushless high-vacuum blower designed to help ensure a long lifespan.

FEATURES

- Simple operation
- Long-life, low-cost replacement filters
- Low noise level



Approvals: UKCA and CE | cUL | UL*

TECHNICAL SPECIFICATION

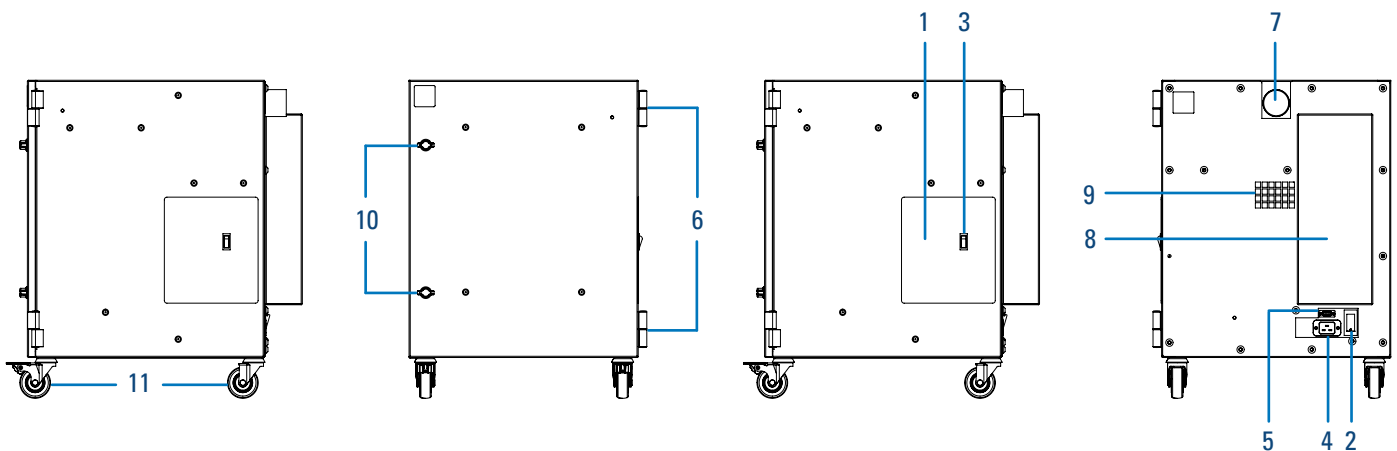

- | | |
|--------------------------------------|---|
| 1. Control panel | 7. Hose inlet connection - 2.0" (50 mm) |
| 2. On/off switch | 8. Exhaust outlet |
| 3. Override switch (optional) | 9. Blower cooling inlet |
| 4. Power cable inlet | 10. Door latches |
| 5. Signal/interface cable (optional) | 11. Castors |
| 6. Door hinges | |

TECHNICAL DATA

Voltage	Airflow		Pressure (+/- 10%)	Dimensions (H x W x D)		Weight (+/- 5%)		Noise level**	Frequency	Full load current
	V	cfm		m ³ /hr	mbar	in	mm			
115-230	167	285	96	23.2 x 18.1 x 21.1	590 x 460 x 535	72.8	33	< 66	50/60	12.5

AIRFLOW

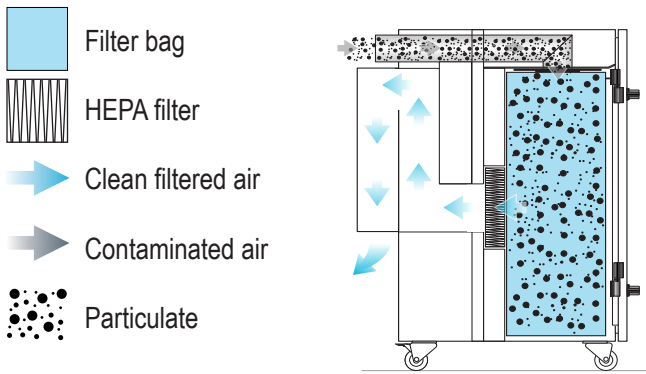

PART NUMBERS - SYSTEM

Description	Part number
Powder-coated, 115-230 V No options	1U30821047-1119
Powder-coated, 115-230 V 24 V S/S, SOK and O/R	1U4680821047-1119
Powder-coated, 115-230 V USA plug	1U10821047-1119
Powder-coated, 115-230 V Exhaust spigot	1U296250821047-1119-01

FILTER SPECIFICATIONS

Model	Surface media area (approx)		Filter efficiency
	ft ²	m ²	
Filter bag	8.6	0.8	99% @ 0.3 microns
HEPA filter	6.5	0.6	99.995% @ 0.3 microns

PART NUMBERS - FILTERS

Filter bag	HEPA filter
1UA1030170	1UA1030161

CUSTOMIZATIONS

Options

Power cables
 Remote stop/start signal (S/S)
 System OK signal (SOK)
 Override (O/R)
 Exhaust box/exhaust spigot

Cabinet construction

Powder-coated mild steel (RAL7035)

Power cables

Type B
 Type E
 Type G

Compatible accessories:

AD Cyclone

*UL: Tested to UL standards, but testing may be provided by alternate nationally recognized test laboratories. Certain product configurations may affect the UL certification. Please speak to your sales representative.

** Noise level: At typical operating speed.

Datasheet correct at time of publishing. Where applicable, the carbon used in Donaldson BOFA systems is capable of removing a wide range of VOCs, however it is the responsibility of the user to ensure the carbon is suitable for their application. For specific applications, please contact us for details.

Important Notice

Many factors beyond the control of Donaldson can affect the use and performance of Donaldson products in a particular application, including the conditions under which the product is used. Since these factors are uniquely within the user's knowledge and control, it is essential the user evaluate the products to determine whether the product is fit for the particular purpose and suitable for the user's application. All products, product specifications, availability and data are subject to change without notice, and may vary by region or country.



Approvals: REACH and RoHS. See individual product technical data for specific accreditations.

Donaldson
BOFA™

Donaldson BOFA

UK & ROW

Tel. +44 (0) 1202 699 444
 Email. bofasales@donaldson.com
 Web. donaldsonbofa.com

Germany

Email. bofavertrieb@donaldson.com

USA

Tel. +1 (618) 205 5007
 Email. bofasalesus@donaldson.com

ENG (May 2026) Donaldson BOFA DustPRO Universal Datasheet. ©2011-2026 Donaldson Company, Inc. Donaldson, Torit, Dalamatic, Delta P, Delta P Plus, Downflo, Dura-Life, Easy Duct, PowerCore, Syntex XP, Ultra-Web, Unimaster and the color blue are marks of Donaldson Company, Inc. All other marks belong to their respective owners.