

AD Base 2 Oracle

Fume Extraction System - Advantage Range

Datasheet

Technical Specification and Product Information

A ride-on fume extraction system for laser engraving.

The AD Base 2 Oracle is a ride-on fume extraction system for laser engraving that offers high performance in a convenient ride-on format. Its larger platform, compared to the AD Base 1 Oracle, makes it ideal for larger laser beds, allowing the laser extractor to double as a workstation.

FEATURES

- Low noise level
- Ride-on system
- Large platform
- Blower with high airflow and pressure



Approvals: UKCA and CE

TECHNICAL SPECIFICATION

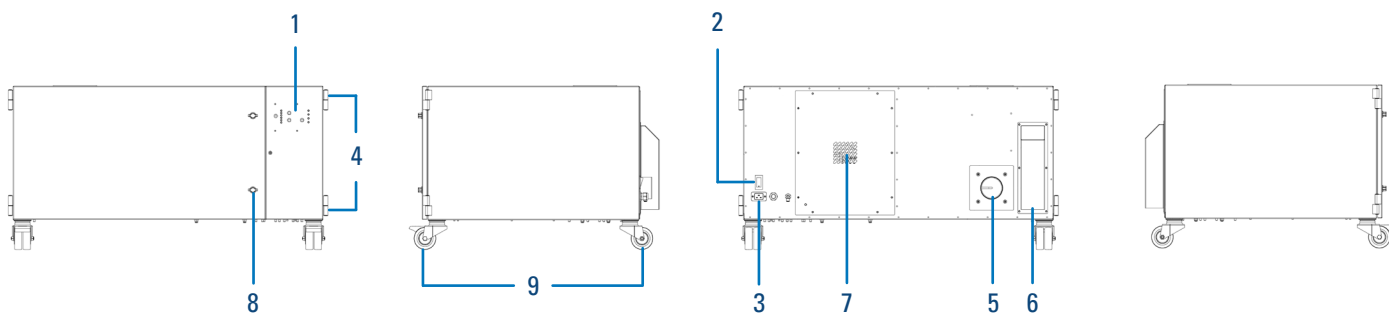

- | | |
|--|-------------------------|
| 1. Control panel | 6. Exhaust outlet |
| 2. On/off switch | 7. Blower cooling inlet |
| 3. Power cable | 8. Door latches |
| 4. Door hinges | 9. Castors |
| 5. Hose inlet connection - 2.9" (75mm) | |

TECHNICAL DATA

Voltage	Airflow		Pressure (+/- 10%)	Dimensions (H x W x D)		Weight (+/- 5%)		Noise level*	Frequency	Full load current
	V	cfm		m ³ /hr	mbar	in	mm			
115-230	223	380	96	21.7 x 41.7 x 31.9	550 x 1060 x 810	207	94	< 63	50/60	12.5
115									50	12

AIRFLOW

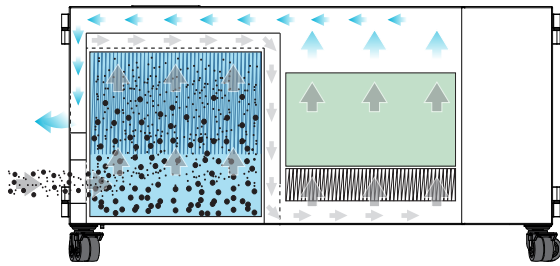
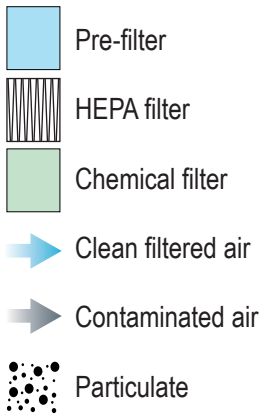

FILTER SPECIFICATIONS

Model	Surface media area (approx)		Filter efficiency
	ft ²	m ²	
DeepPleat DUO pre-filter	129.1	12	ePM1 70%
Combined filter (HEPA)	49.5	4.6	99.995% @ 0.3 microns

Model	Activated carbon volume	
	ltr	
Combined filter (gas)	15.5	

PART NUMBERS - FILTERS

DeepPleat DUO pre-filter	Combined filter
1UA1030156	1UA1030155

Datasheet correct at time of publishing. Where applicable, the carbon used in Donaldson BOFA systems is capable of removing a wide range of VOCs, however it is the responsibility of the user to ensure the carbon is suitable for their application. For specific applications, please contact us for details.

Important Notice

Many factors beyond the control of Donaldson can affect the use and performance of Donaldson products in a particular application, including the conditions under which the product is used. Since these factors are uniquely within the user's knowledge and control, it is essential the user evaluate the products to determine whether the product is fit for the particular purpose and suitable for the user's application. All products, product specifications, availability and data are subject to change without notice, and may vary by region or country.



Approvals: REACH and RoHS. See individual product technical data for specific accreditations.



Donaldson BOFA

UK & ROW
Tel. +44 (0) 1202 699 444
Email. bofasales@donaldson.com
Web. donaldsonbofa.com

Germany
Email. bofavertrieb@donaldson.com

USA
Tel. +1 (618) 205 5007
Email. bofasalesus@donaldson.com

ENG (April 2026) Donaldson BOFA AD Base 2 Oracle Datasheet. ©2011-2026 Donaldson Company, Inc. Donaldson, Torit, Dalamatic, Delta P, Delta P Plus, Downflo, Dura-Life, Easy Duct, PowerCore, Syntex XP, Ultra-Web, Unimaster and the color blue are marks of Donaldson Company, Inc. All other marks belong to their respective owners.

PART NUMBERS - SYSTEM

Description	Part number
Powder-coated, 115-230 V No options	1U30811014-1453
Powder-coated, 115 V No options	1U30810514-1453

CUSTOMIZATIONS

Options

Power cables
Remote stop/start signal (S/S)
System OK signal (SOK)
Override (O/R)
VOC sensor
Onboard compressor (COMP)

Cabinet construction

Powder-coated mild steel (RAL7016)

Power cables

Type B
Type E
Type G

* Noise level: At typical operating speed.