

# AD Base 1 Oracle

Fume Extraction System - Advantage Range

## Datasheet

Technical Specification and Product Information

### A ride-on fume extraction system for laser engraving.

The AD Base 1 Oracle is a ride-on fume extraction system for laser engraving. It delivers high performance in a convenient ride-on format, allowing the laser extractor to function as a workstation.

### FEATURES

- Low noise levels
- Ride-on system
- Blower with high airflow and pressure

Approvals: UKCA and CE



### TECHNICAL SPECIFICATION

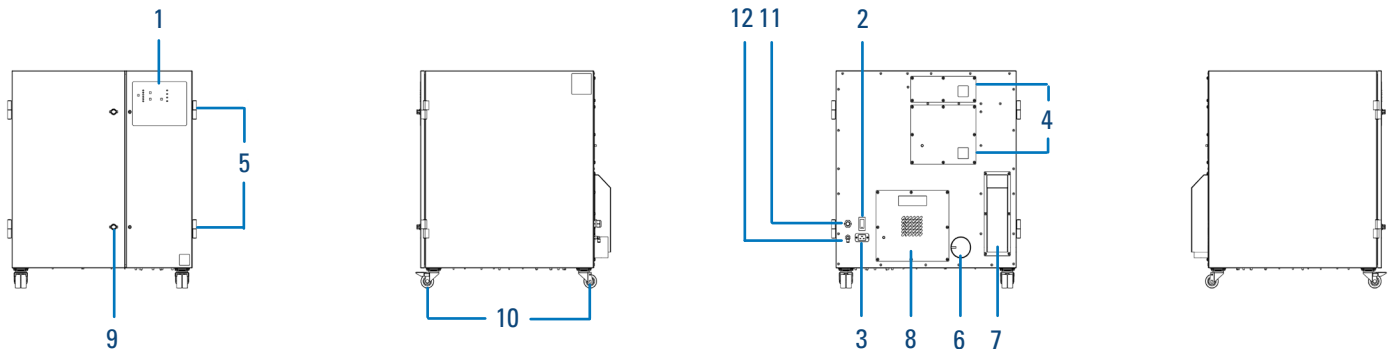

- |  |                                       |
|--|---------------------------------------|
| 1. Control panel                       | 7. Exhaust outlet                     |
| 2. On/off switch                       | 8. Blower cooling inlet               |
| 3. Power cable inlet                   | 9. Door latches                       |
| 4. Blower access panel                 | 10. Castors                           |
| 5. Door hinges                         | 11. Signal/interface cable (optional) |
| 6. Hose inlet connection - 2.9" (75mm) | 12. Compressed air outlet (optional)  |

### TECHNICAL DATA

Voltage	Airflow		Pressure (+/- 10%)	Dimensions (H x W x D)		Weight (+/- 5%)		Noise level*	Frequency	Full load current
	V	cfm		m <sup>3</sup> /hr	mbar	in	mm			
115-230	224	380	96	31.1 x 28.9 x 29.1	790 x 735 x 740	189	86	< 64	50/60	12.5

## AIRFLOW

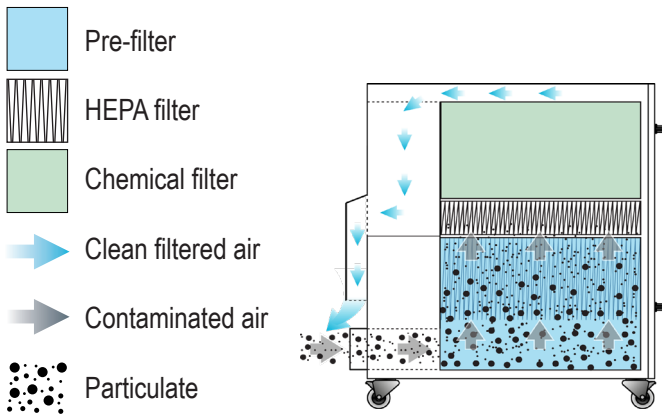

## FILTER SPECIFICATIONS

Model	Surface media area (approx)		Filter efficiency
	ft <sup>2</sup>	m <sup>2</sup>	
DeepPleat DUO pre-filter	129.1	12	ePM1 70%
Combined filter (HEPA)	49.5	4.6	99.995% @ 0.3 microns

Model	Activated carbon volume	
	ltr	
Combined filter (gas)	15.5	

## PART NUMBERS - FILTERS

DeepPleat DUO pre-filter	Combined filter
1UA1030156	1UA1030155

## PART NUMBERS - SYSTEM

Description	Part number
Powder-coated, 115-230 V No options	1U30811013-1462
Powder-coated, 115-230 V COMP	1U30811013-1462-1

## CUSTOMIZATIONS

### Options

Power cables  
 Remote stop/start signal (S/S)  
 System OK signal (SOK)  
 Override (O/R)  
 VOC sensor  
 Onboard compressor (COMP)

### Power cables

Type B  
 Type E  
 Type G

### Cabinet construction

Powder-coated mild steel (RAL7016)

\* Noise level: At typical operating speed.

Datasheet correct at time of publishing. Where applicable, the carbon used in Donaldson BOFA systems is capable of removing a wide range of VOCs, however it is the responsibility of the user to ensure the carbon is suitable for their application. For specific applications, please contact us for details.

#### Important Notice

Many factors beyond the control of Donaldson can affect the use and performance of Donaldson products in a particular application, including the conditions under which the product is used. Since these factors are uniquely within the user's knowledge and control, it is essential the user evaluate the products to determine whether the product is fit for the particular purpose and suitable for the user's application. All products, product specifications, availability and data are subject to change without notice, and may vary by region or country.



Approvals: REACH and RoHS. See individual product technical data for specific accreditations.

**Donaldson**  
BOFA™

#### Donaldson BOFA

**UK & ROW**  
 Tel. +44 (0) 1202 699 444  
 Email. [bofasales@donaldson.com](mailto:bofasales@donaldson.com)  
 Web. [donaldsonbofa.com](http://donaldsonbofa.com)

**Germany**  
 Email. [bofavertrieb@donaldson.com](mailto:bofavertrieb@donaldson.com)

**USA**  
 Tel. +1 (618) 205 5007  
 Email. [bofasalesus@donaldson.com](mailto:bofasalesus@donaldson.com)

ENG (April 2026) Donaldson BOFA AD Base 1 Oracle Datasheet. ©2011-2026 Donaldson Company, Inc. Donaldson, Torit, Dalamatic, Delta P, Delta P Plus, Downflo, Dura-Life, Easy Duct, PowerCore, Synteq XP, Ultra-Web, Unimaster and the color blue are marks of Donaldson Company, Inc. All other marks belong to their respective owners.