

DustPRO 1000 iQ

Fume Extraction System - DustPRO Range

Datasheet

Technical Specification and Product Information

A system for medium to heavy-duty industrial applications.

The DustPRO 1000 iQ extraction system is ideal for medium to heavy-duty applications that generate large amounts of particulate. With a greater airflow than the DustPRO 500 iQ, it also offers significant filter capacity.

FEATURES

- Long-life, low-cost replacement filters
- High contrast display
- Remote diagnostics via USB

Approvals: UKCA and CE | cUL | UL*



TECHNICAL SPECIFICATION

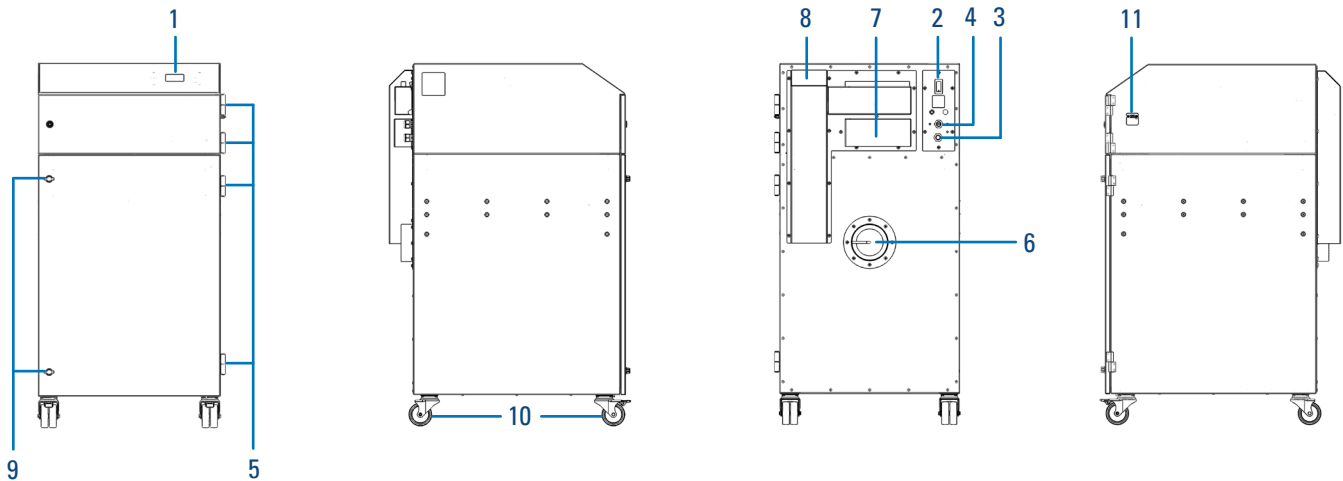

- | | | |
|---------------------------|---|-----------------|
| 1. iQ display | 5. Door hinges | 9. Door latches |
| 2. On/off switch | 6. Hose inlet connection - 4.92" (125 mm) | 10. Castors |
| 3. Power cable | 7. Blower cooling inlet | 11. USB port |
| 4. Signal/interface cable | 8. Air outlet/blower cooling outlet | |

TECHNICAL DATA

Voltage	Unrestricted airflow** (+/- 10%)		Settable airflow range***		Pressure (+/- 10%)	Dimensions (H x W x D)		Weight (+/- 5%)		Noise level****	Frequency	Full load current
	V	cfm	m ³ /hr	cfm		m ³ /hr	in	mm	lbs			
230	520	885	176-442	300-750	60	47.4 x 24.2 x 31.9	1205 x 620 x 810	209	95	< 60	50/60	12.8

AIRFLOW

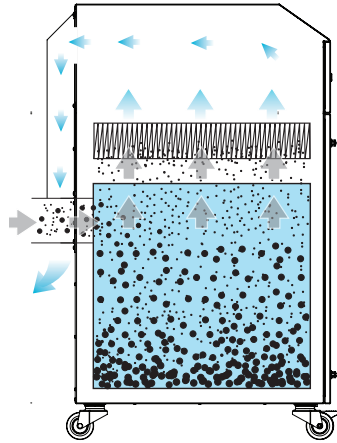
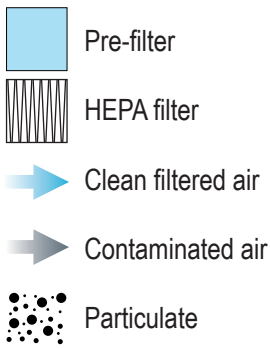

PART NUMBERS - SYSTEM

Description	Part number
Powder-coated, 230 V UK plug	1U30811619-A-2181-UK
Powder-coated, 230 V EU plug	1U30811619-A-2181-EU
Powder-coated, 230 V 24 V S/S, SOK, O/R, UK plug	1U6530811619-A-2181-UK
Powder-coated, 230 V 24 V S/S, SOK, O/R, EU plug	1U6530811619-A-2181-EU
Powder-coated, 230 V 24 V S/S, SOK, O/R, USA plug	1U6530811619-A-2181-US

FILTER SPECIFICATIONS

Model	Surface media area (approx)		Filter efficiency
	ft ²	m ²	
Pre-filter bag	44.1	4.1	95% @ 0.9 microns
HEPA filter	80.7	7.5	99.995% @ 0.3 microns

PART NUMBERS - FILTERS

Pre-filter bag	HEPA filter
1UA1030395	1UA1030394

CUSTOMIZATIONS

Options

Power cables
Remote stop/start signal (S/S)
System OK signal (SOK)
Override (O/R)
Exhaust box

Cabinet construction

Powder-coated mild steel (RAL7016)

Power cables

Type B
Type E
Type G

*cUL | UL: Tested to the appropriate standards, but testing may be provided by alternate nationally recognized test laboratories. Certain product configurations may affect the certification. Please speak to your sales representative.

** Unrestricted airflow: The airflow values provided with clean filters, no hose kit, at 230 V, measured by using a wind vane. The numbers may vary depending on voltage and test procedure used.

*** Settable range: Donaldson BOFA recommends utilizing the lowest flow rate that achieves the correct capture velocity for your application in order to maximize filter life.

**** Noise level: At typical operating speed.

Datasheet correct at time of publishing. Where applicable, the carbon used in Donaldson BOFA systems is capable of removing a wide range of VOCs, however it is the responsibility of the user to ensure the carbon is suitable for their application. For specific applications, please contact us for details.

Important Notice

Many factors beyond the control of Donaldson can affect the use and performance of Donaldson products in a particular application, including the conditions under which the product is used. Since these factors are uniquely within the user's knowledge and control, it is essential the user evaluate the products to determine whether the product is fit for the particular purpose and suitable for the user's application. All products, product specifications, availability and data are subject to change without notice, and may vary by region or country.



Approvals: REACH and RoHS. See individual product technical data for specific accreditations.

FS 643451
ISO 9001

Donaldson
BOFA™

Donaldson BOFA

UK & ROW

Tel. +44 (0) 1202 699 444
Email. bofasales@donaldson.com
Web. donaldsonbofa.com

Germany

Email. bofavertrieb@donaldson.com

USA

Tel. +1 (618) 205 5007
Email. bofasalesus@donaldson.com

ENG (April 2026) Donaldson BOFA DustPRO 1000 iQ Datasheet. ©2011-2026 Donaldson Company, Inc. Donaldson, Torit, Dalamatic, Delta P, Delta P Plus, Downflow, Dura-Life, Easy Duct, PowerCore, Synteq XP, Ultra-Web, Unimaster and the color blue are marks of Donaldson Company, Inc. All other marks belong to their respective owners.