



A Donaldson Company

AD BASE 2 ORACLE FUME EXTRACTOR

LAST UPDATED ON 07.09.2024

A WORLD LEADER IN FUME
EXTRACTION TECHNOLOGY

Adapting the AD Base 1 Oracle extraction system, this unit sits lower to allow larger bed lasers to be placed securely on top while giving a direct extraction system.

This system also benefits from a DeepPleat DUO pre-filter and multi-voltage sensing unit.

As with all our Base systems, this unit has the option of an onboard compressor for a compact installation.

Key features

- Reverse flow filter technology
- Automatic flow control
- Auto-sensing voltage (100-230v) for global use
- DeepPleat DUO pre-filter
- Advanced carbon filter technology
- HEPA and gas combined filter
- 'Easi-seal' filter location
- Small footprint
- Low noise level
- Optional VOC (volatile organic compound) gas sensor
- Optional onboard compressor
- Optional remote stop/start interface
- Optional filter change/system fail signal



DeepPleat
DUO pre-
filter



HEPA
filter



Advanced
carbon
filter (ACF)
technology



Automatic flow
control (AFC)
technology



Reverse flow
air (RFA)
technology



Multi-voltage
sensing unit
(MVS)



SureCHECK
quality
standard



Patented
technology

Technical specification

1. Unit/filter condition display - automatic flow control
2. On/off switch
3. Standby button
4. Power cable inlet
5. Castors
6. Door hinge
7. Hose inlet connection - 2.95"/75mm
8. Exhaust outlet
9. Motor cooling inlet

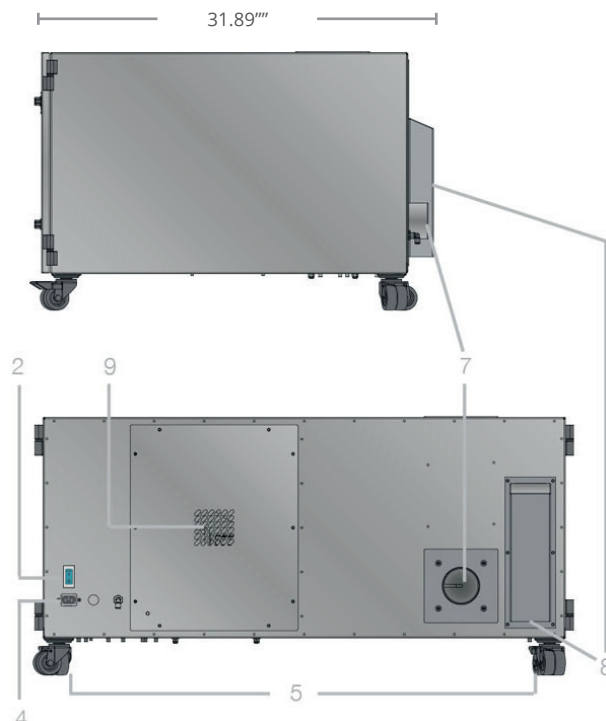
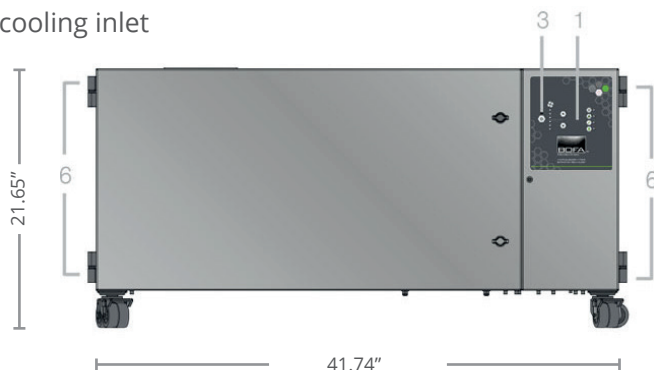

Airflow through filters

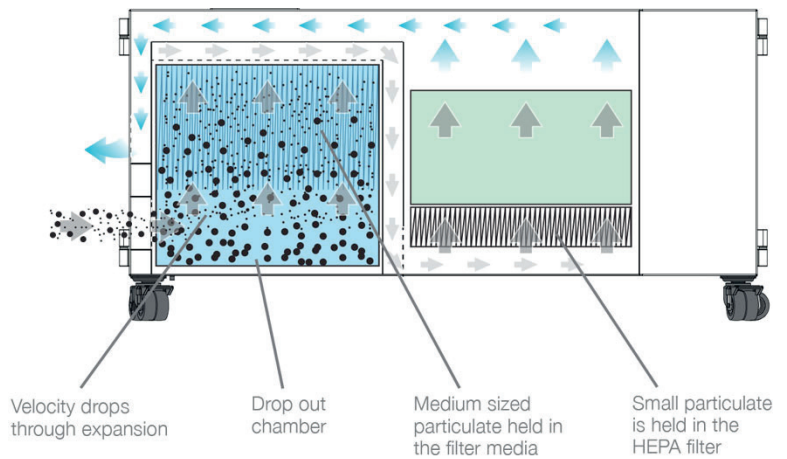

Technical data

Dimensions (HxWxD)	21.65 x 41.74 x 31.89"
Cabinet construction	Powder-coated mild steel
Airflow/pressure	223cfm/96mbar
Electrical data	100-230v single-phase 1~ 50/60Hz Full load current: 12.5 amps/1.1kw
	115v Single-phase 1~ 50/60Hz Full load current: 12 amps
Noise level	< 63 dBA (at typical operating speed)
Weight (standard extractor with filters)	207lbs (+/- 5%)
Approvals	UKCA and CE

Pre-filter specifications (DeepPleat DUO)

Surface media area	Approx 129.12 ft ²
Filter media	Borosilicate
Filter media construction	Pleated with glue bead spacers
Filter housing	Zintec mild steel
Filter efficiency	95% @ 0.3 microns
Inlet size	75mm (0.24ft)
Dropout chamber size	16.2 liters
Filter media pleat size	200mm (0.65 ft)

Combined HEPA/gas filter specifications

HEPA filter media	Borosilicate
HEPA media construction	Maxi pleat construction with glue bead spacers
Gas filter	Treated activated carbon
Treated activated carbon	33 lbs
Filter efficiency	99.995% @ 0.3 microns

Part numbers

Model	AD Base 2 Oracle - Powder-coated
Part number	1U30810514-1453
Optional internal compressor	1UA1050043
Single hose kits	1USHK-B2-(3,4)
Optional exhaust spigot 75mm	1UA1060074
Replacement filters	
Pre-filter	1UA1030156
Combined HEPA/gas filter	1UA1030155

Contact BOFA at donaldsonbofa.com/contact/

Datasheet correct at time of publishing.

Where applicable, the carbon used in BOFA units is capable of removing a wide range of VOCs, however it is the responsibility of the user to ensure the carbon is suitable for their application. For specific applications, please contact us for details.

Important notice: Many factors beyond the control of BOFA can affect the use and performance of BOFA products in a particular application, including the conditions under which the product is used. Since these factors are uniquely within the user's knowledge and control, it is essential the user evaluate the products to determine whether the product is fit for the particular purpose and suitable for the user's application. All products, product specifications, availability and data are subject to change without notice, and may vary by region or country.

Think before you print! Please consider the environment before printing this document.



Approvals: REACH and RoHS.
See individual product technical data for specific accreditations.

