



A Donaldson Company

A WORLD LEADER IN FUME
EXTRACTION TECHNOLOGY

AD Access

USER MANUAL



Contents

1	01	Overview of your AD Access extraction system (front)
	02	Overview of your AD Access extraction system (back)
	03	Overview of the control panel
2	01	Important safety notes
	02	Safety labels
3	01	Unpacking and unit placement
4	01	Fume capture methods
	02	Connecting to power supply
	03	Optional added features
5	01	Turning extractor on
6	01	Cleaning the unit & general maintenance information
	02	Filter replacement
7	01	Consumable spares / filter disposal
8	01	AD Access specifications

Overview

1 01



Overview

1 02



Overview

1 03

Company Branding

Blocked



Filter 75% Full

Clean Running

Safety Instructions



Important safety notes

Concerning symbols used on the extraction unit and referred to within this manual.



Danger

Refers to an immediately impending danger. If the danger is not avoided, it could result in death or severe (crippling) injury. Please consult the manual when this symbol is displayed.



Warning

Refers to a possibly dangerous situation. If not avoided it could result in death or severe injury. Please consult the manual when this symbol is displayed.



Caution

Refers to a possibly harmful situation. If not avoided, damage could be caused to the product or something in its environment.



Important (Refer to manual)

Refers to handling tip and other particularly useful information. This does not signify a dangerous or harmful situation. Refer to manual when this symbol is displayed.

Electrical Safety

The unit has been designed to meet the Essential Health and Safety Requirements of the Machinery Directive 2006/42/EC

Warning

When working with the pump/motor housing open, Live 230/115 volt mains components are accessible. Ensure that the rules and regulations for work on live components are always observed.

Important

To reduce the risk of fire, electric shock or injury:

1. Always isolate the system from the mains power supply before removing the pump/motor access panel.
2. Use only as described in this manual.
3. Connect the system to a properly grounded outlet.

Dangers to eyes, breathing and skin

Once used, the filters within the system may contain a mixture of particulates, some of which may be sub-micron size. When the used filters are moved it may agitate some of this particulate, which could get into the breathing zone and eyes of the operative. Additionally, depending on the materials being processed, the particulate may be an irritant to the skin.

Carbon selection

Please note that the media within the gas filter fitted in the system is capable of adsorbing a wide range of organic compounds. However, it is the responsibility of the user to ensure it is suitable for the particular application it is being used on.

Intended use

This equipment has been designed to extract and filter fume from a variety of applications. However it is the users responsibility to ensure the equipment is installed correctly and is suitable for the application. This machine must not be used on wet applications or acidic fumes.

BOFA Technical Service

If a problem arises with your system please contact us by:

- Visiting our website at www.bofainternational.com for on-line help.
- Or contacting the helpline on **+44 (0) 1202 699 444**, Mon-Fri, 9am-5pm.
Email: Technical@bofa.co.uk

Safety Instructions



Warning and Information labels

The following listing details labels used on your unit.

Goggles, Gloves & Mask Label



Location:

Front face of filters.

Meaning: Goggles, Gloves and Masks should be worn while handling used filters.



Do Not Cover Label

Location: Underside of unit.

Meaning: Do not cover any louvers or holes adjacent to the label.



Electrical Danger

Location: Motor access panel.

Meaning: Removal of panels with this label attached will allow access to potentially live components.

Warning Label



Location: Centre right side on top of unit.

Meaning: Power should be isolated before the panel is opened/ removed.

Serial Number

For future reference, fill in your system details in the space provided. The serial number is on the rating label located on the side/rear of the unit.

Serial Number:

A	D	A	C	C	E	S	S	-												

Serial Number Label



Location: Rear of unit, above mains inlet.

Meaning: This label contains a variety of information about the extraction unit, including.

- Company name, Address & Contact number
- Extractor model
- Unit serial number
- Operating voltage range
- Maximum current load
- Operating frequency
- Year of Manufacture
- Relevant approval markings/ logos

Fire Risk Warning

In the very rare event that a burning ember or spark is drawn into the fume extraction unit, it may be possible that the filters will ignite.

Whilst any resultant fire would typically be retained within the fume extraction unit, the damage to the extractor could be significant.

It is therefore essential to minimise the possibility of this occurring by undertaking an appropriate Risk assessment to determine:-

- a). Whether additional fire protection equipment should be installed.
- b). Appropriate maintenance procedures to prevent the risk of build-up of debris which could potentially combust.

This unit should not be used on processes where sparks could occur, with explosive dusts and gases, or with particulates which can be pyrophoric (can spontaneously ignite), without implementation of additional precautions

It is essential that nozzles or other extraction/ fume capture devices and hoses/pipework are cleaned regularly to prevent the build-up of potentially ignitable debris

Before installation

3₀₁

Packaging Removal & Unit Placement

Before installation, check the extraction unit for damage.

All packaging must be removed before the unit is connected to the power supply.

Please read all instructions in this manual before using this extractor.

1. Move the unit to the location where it is going to be installed and remove the outer packaging. **This unit should be installed in a well-ventilated area.**

Ensure that 500 mm space is available around any vented panels on the extractor to ensure adequate airflow.

2. Check the filter is located in its correct position before replacing the lid and securing the clips



Caution

Due to the weight of the extractor suitable lifting equipment should be used and with regard to appropriate safety precautions. (See Appendix for product weight details)



Caution

Do not block or cover the cooling vents on the unit, as this severely restricts airflow and may cause damage to the unit.



Caution

Under no circumstances should the exhaust outlet/s be covered as this will restrict the airflow and cause overheating.

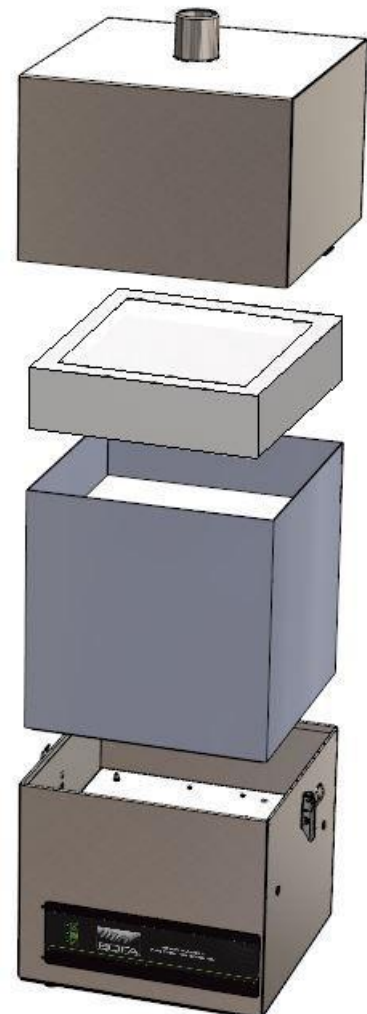

Installation

4⁰¹

The system has been designed to remove and filter fume containing potentially hazardous particulate and gases generated during manufacturing processes. Such hazardous substances are captured within a multistage filtration system after which the cleaned air is returned to the workplace.

Fume Capture Methods

The fume is normally captured by 1 of 3 methods.

- Flexible arm/ Nozzle
- Enclosures
- Cabinets

General Guidelines for a successful installation

- Keep duct run length to a minimum
- Avoid sharp bends / turns in the ductwork
- Avoid multiple bends / turns in the ductwork
- Use a larger diameter duct where able
- Position the capture device as close as possible to the marking point. (if used on high speed lines, position the capture device slightly downstream)

Flexible Arm & Nozzle Extraction

The stay put arm should be mounted as close as possible to the marking point using the horseshoe clips. Unscrew the push fit connector from the other side of the flexible hose. Cut the flexible hose to suit the distance back to the extractor connection and push onto the extractor inlet.

Purge air should be kept to a minimum, where possible, to prevent the fume being blown away from the nozzle.

High speed production lines may need bigger scoops or nozzles both sides of the product because of the turbulence caused by the speed of the lines.

Moving products

For applications where the product to be marked is moving past the stationary laser head the capture nozzle should be positioned as close as possible to the

marking area on the side the product is moving towards.

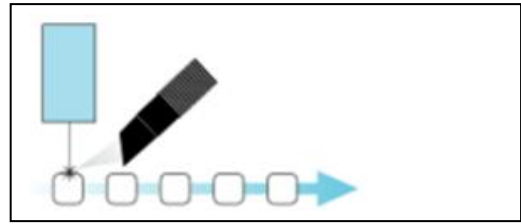

Enclosures

The extraction hose and nozzle can be attached to the enclosure surrounding the marking zone provided that the extraction point is within 50-75mm of the marking point.

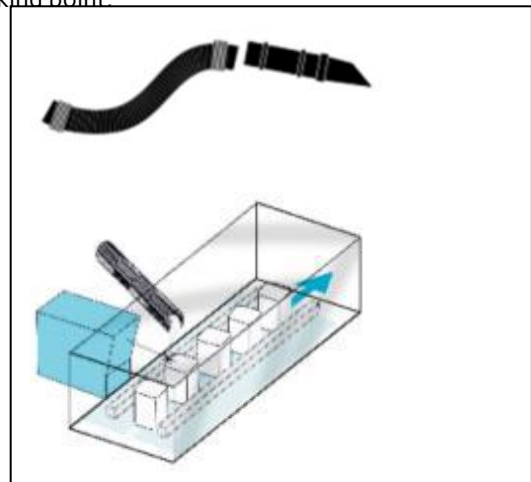

Cabinets

Cabinets normally have a 75mm or 100mm spigot for fume extraction. For best performance use the same diameter hose as the spigot and reduce at the extractor end if necessary. **Keep the hose run as short as possible.**

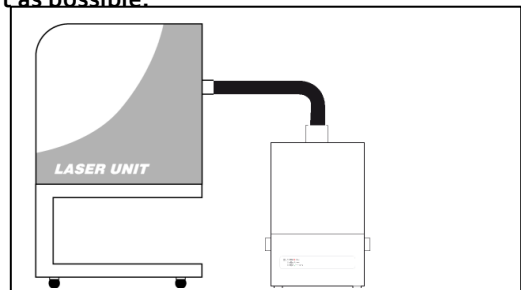

Connection to extraction unit

All ductwork should be installed and connected to the extraction unit before the system is turned on.

Installation

4 02

Specification

Refer to section 08 01.

Connection to Power Supply

Please follow the specification (section 08 01) when selecting the power supply outlet for the system, ensure the power supply is suitable before connecting the system.

Check the integrity of the electrical power cable, if the supply cord is damaged the extraction unit should not be connected to the mains. The supply cord should only be replaced by a BOFA engineer as an electrical safety test may be required after replacement.

The Access system **MUST** be connected to a properly earthed outlet.

Connect the power cable to an isolated electrical supply.



The mains socket should be installed near the extractor it should be easily accessible and able to be switched On/ Off. The cable run should be arranged so as not to create a trip hazard.

Installation

4 03

Optional added features

The system can be configured to suit customer specification. These optional extras would be discussed, arranged and installed prior to delivery. **(If unsure what features your system is equipped with please contact the seller with the unit serial number, (Refer to section 2 for location) who will be able to advise what specification has been supplied.**

Remote Stop/Start feature

Enables the extraction unit to be remotely turned On / Off via an external signal.

Note: Care must be taken to ensure that the system is correctly wired in order for the extraction unit to function correctly.

DC Voltage input

This configuration requires the Black & Red cores of the signal cable (Refer to section 1 for location) to be connected to a known and tested DC power supply, in order to start the extractor.

The operating voltage for this signal is between 12 & 24VDC. Only voltages within this range should be connected. Voltages connected outside of this range may cause irreversible damage to the internal control PCB.

Red cable = V+

Black cable = V-

When the extractor is provided with the correct DC voltage the motor will start and maintain the set flow rate (Refer to section 5 for how to set the flow) when the DC voltage is removed the motor will slow down and come to a stop.

The extractor will need to be turned on (See section 5 for turning the extractor on) in order for this feature to operate.

Override

Enables the extractor to operate fully with or without either DC voltage input or the Volt free input. The override feature can be toggled On / Off by a switch mounted on the internal motor access panel (see image below and section 1.02 for switch location)



Switch in "On" position

In this position the extractor will require a start signal (either Voltage input or Volt free, depending on the requested specification) to enable the motor within the extraction unit.

Switch in "Off" position

In this position the extractor motor will run without the requirement for an external start signal. This feature is useful for engineers carrying out works/ tests on the extractor without the need for the laser / auxiliary signal being present.

Filter Blocked / System Fail Signal

With this option the extraction system will output a signal to alert the user when the extractor has failed or when the filters are blocked.

This feature will not directly stop the extractor from running correctly, but if fitted this feature should be terminated correctly before power is applied to the extraction system.

Connection specification

This signal is available via the Green and White cores of the signal cable. The system will provide a volt free Open / Closed signal that can be connected to an external interface, beacon or warning device following the specification below.

- **Maximum input voltage: 24V AC**
- **Maximum current load: 3A @ AC**
- **OR**
- **Maximum input voltage: 24V DC**
- **Maximum input load: 3A @ DC**

Filter Signal

When the filters become blocked or the system develops a fault the connection between the Green & White cables will become "Open"

When the extraction system is running normally the connection between the Green & White cables will become "Closed"

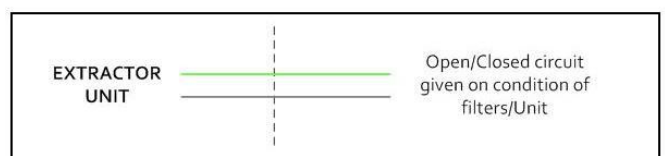

Operation

5₀₁

Turning extraction unit On

Press the main on/off switch to the "On" position
(Refer to section 1 for switch location) by depressing
the red switch.

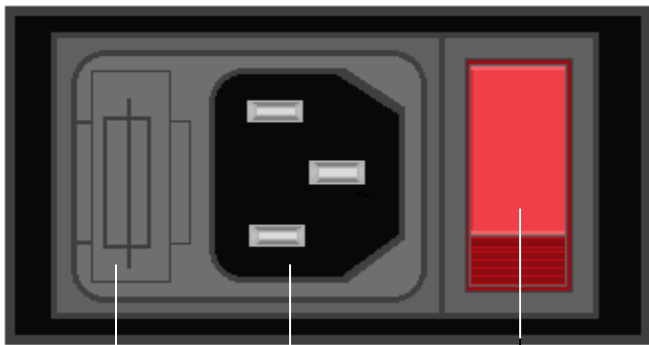

Fuse Tray

On/off Switch

Mains Inlet

Maintenance



Maintenance UK

It is a legal requirement, under regulation 9 of the COSHH regulations that all local exhaust ventilation systems are thoroughly examined and tested at least once every 14 months (typically carried out annually). The approved code of practice recommends that a visual check should be carried out at least once a week.

COSHH requires the annual inspection and testing to be carried out by a competent person and specifies that documentation results are recorded in a log.

Contact the seller for more information about inspection and certification.

Maintenance General

User maintenance is limited to cleaning the unit and filter replacement, only the manufacturers trained maintenance technicians are authorised to carry out component testing and replacement. Unauthorised work or the use of unauthorised replacement filters may result in a potentially dangerous situation and/or damage to the extractor unit and will invalidate the manufacturer's warranty.

Cleaning the unit

The powder coat finish can be cleaned with a damp cloth and non-aggressive detergent, do not use an abrasive cleaning product as this will damage the finish.

The cooling inlets and outlets should be cleaned once a year to prevent build-up of dust and overheating of the unit.

Filter Information

A log of filter changes should be maintained by the user.

The filters require attention when the red alarm LED glows, or when the extractor no longer removes fume efficiently.

It is recommended that a spare set of filters are kept on site to avoid prolonged unit unavailability. Part numbers for replacement filters can be found on the filters fitted in your system.

To prevent overheating, units should not be run with a blocked filter condition, or with dust obstruction of Inlets Outlets.

Maintenance

6₀₂

Filter Replacement

Refer to section 2.02 for PPE requirements.

During use, the extractor will alert the user when its filter needs replacing. When the filter is 75% full, both the green and amber LEDs will glow.



When the filter is full/blocked, the red LED on the control panel will glow. All three LEDs will be glowing as shown below. A filter change is required at this stage.



To remove and replace the pre filter follow the procedure detailed below.

1. Isolate the electrical supply to the extractor
2. Undo the two clips on the sides of the unit and remove the lid.
3. Lift the pre filter out of the unit. Once removed it is recommended that the used filters are bagged and sealed.
4. Lower the new pre filter into position. Replace the lid, and fasten the two clips.

Note: The filters MUST be fitted when the extractor is in use.

To remove and replace the combined filter follow the procedure detailed below.

1. Isolate the electrical supply to the extractor
2. Undo the two clips on the sides of the unit and remove the lid.
3. Lift the pre filter, then the combined filter out of the unit. Once removed it is recommended that the used filters are bagged and sealed.
4. Lower the new combined filter into position followed by the pre filter. Replace the lid, and fasten the two clips.

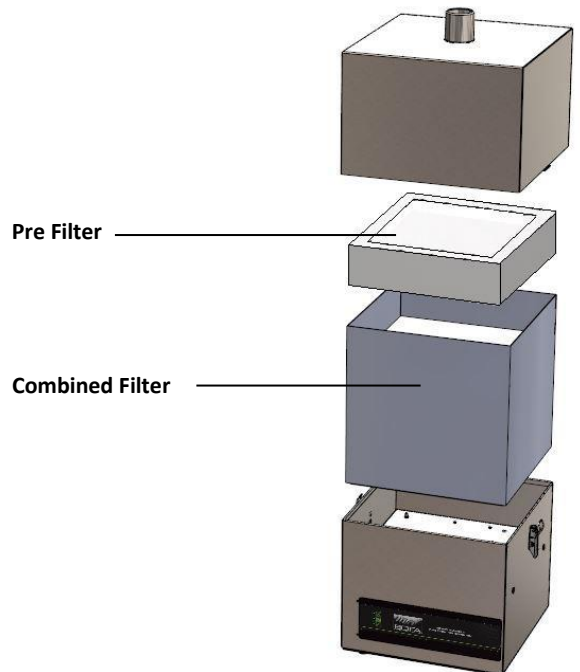

Flashing LEDs

Flashing LEDs indicate a loss of vacuum inside the extraction unit. In the event of this, please contact your local representative or Contact BOFA. Contact details are found at the back of this manual. This may also occur as the unit starts up. (if the unit has remote stop/start then these LED's will flash while the unit is idle waiting for the start signal)



Replacement Parts



Consumable Spares

The extraction system contains a pre filter and a combined filter. These should be replaced when instructed to do so by the Access system (see section 6 for replacing the filters) or when the extractor is not performing efficiently

To maintain performance it is important that the filters are replaced with identical BOFA filters. To re-order please refer to the Filter number printed on the filter installed in your extraction unit.

Maintenance Protocol

Users may wish to record Filter changes on the table below.

Unit Serial Number:			
Pre filter		Combined filter	
Date	Engineer	Date	Engineer

Filter disposal

The Pre and Combined filters are manufactured from non-toxic materials. Filters are not re-usable, cleaning used filters is not recommended. The method of disposal of the used filters depends on the material deposited on them.

For your guidance

Deposit	EWC Listing*	Comment
Non Hazardous	15 02 03	Can be disposed of as non-hazardous waste.
Hazardous	15 02 02M	The type of hazard needs to be identified and the associated risks defined. The thresholds for these risks can then be compared with the amount of material in the filters to see if they fall into the hazardous category, if so, the filters will need to be disposed of in line with the local/national regulations.

*European Waste Catalogue

Fuses

The Extraction unit has a fused mains Inlet/Isolation switch protecting the entire unit. Should a replacement fuse be required it is important that this matches the specification given below.

Unit	Fuse Rating	Full load current	Voltage
AD Access	T2AH250V (2A)	<1.2A	110/230V

System Specifications

Wiring schematic available upon request

Spares parts list available upon request



Unit: AD ACCESS

Capacity: 180 m³/h (105cfm)

Weight: 24Kg (52.9lbs)

Motor: Centrifugal Fan

Output: 230v: 140w 115v: 107w

Electrical supply: 115/230V

Hertz: 230v 1ph 50hz (115v 1ph 60Hz)

Full Load Current: 230v: 1.5A 115v: 1.5A

No of phases: 1

Noise Level: Below 61dB (A)

(at typical operating speed)

61010 Stability test results:

Size:

	Metric (mm)	Imperial (inches)
Height	465	18.3
Depth	310	12.2
Width	320	12.6

Filters:

Filter Type	Surface area	Efficiency
Pre filter	2.0 m ²	94% @ 0.9micron
Combined filter	2.0m ²	99.997% @ 0.3micron

Combined Filter (Gas section)

Filter Type	Carbon type	Amount
Combined filter (Gas)	Activated carbon	7kgs

Environmental operating range:

Temperature: +5°C to + 40°C

Humidity: Max 80% RH up to 31°C

Max 50% RH at 40°C

Contact Information

BOFA Headquarters

19-20 Balena Close
Creekmoor industrial Estate
Poole
Dorset
BH17 7DU
UK
Tel. +44 (0) 1202 699 444

Email. sales@bofa.co.uk

German Office

Sudring 62
D-21465
Wentorf bei Hamburg
Germany
Tel. +49 (0) 40 739 3735-15
Email. vertrieb@bofa.co.uk

BOFA Americas, Inc

303 S.Madison Street
Staunton
Illinois
62088
USA
Tel. +1 (618) 205 5007
Email. sales@bofaamericas.com



A WORLD LEADER IN FUME
EXTRACTION TECHNOLOGY

E C DECLARATION OF CONFORMITY

Manufacturer: BOFA International Ltd,
Address: 21-22 Balena Close,
Creekmoor Ind Estate,
Poole, Dorset.
BH17 7DX.

Country of origin: England, United Kingdom

Product: Fume Extraction Unit
AD Access

Serial Number:

The named product is in conformity with the requirements of the following European Directives:

2006/42/EC Machinery Directive
2014/30/EU EMC Directive
2011/65/EU RoHS Directive

Conformity with the requirements of the directives is testified by adherence to the relevant parts of the following harmonised standards:

BS EN 60204-1:2018	Electrical equipment of machines
BS EN ISO 12100:2010	Risk assessment and risk reduction
BS EN 61000-3-2:2014	EMC limits for Harmonics
BS EN 61000-3-3:2013	EMC limits for Voltage fluctuations & flicker
BS EN 61000-6-2:2005	EMC immunity requirements
BS EN 61000-6-4:2011	EMC emission requirements

Paul Beeson – Product Certifications
BOFA International Ltd – Balena Close Poole BH17 7DX

Tony Lockwood, Managing Director
For and on behalf of BOFA International Ltd
1st Jan 2020





Local Exhaust Ventilation System - **Inspection Record**

Health & Safety at Work Act 1974 - Control of Substances Hazardous to Health - Regulation 9 (2002)
Thorough Examination and Testing of Local Exhaust Ventilation Systems

Company:	System Designation:	System Installation Date:
Designated Person:		

Inspection and Maintenance Schedules

1. Daily checks
2. Weekly inspection of process enclosure, extract offtake, hose/ducting and extract/filtration unit.
3. Monthly inspection of process enclosure, extract offtake, hose/ducting and extract/filtration unit.
4. Yearly inspection / testing

**Process enclosure, extract offtake(s), hose/ducting and extract/filtration unit.
Inspection and Maintenance Record**

1. Daily inspection

Inspection of the process to ensure extract devices/nozzles/enclosures/hoses are in place and correctly positioned. Examination of the extractor to ensure it is running. This to be carried out by the operator. Daily inspection not recorded.

2. Weekly Inspection

Weekly inspection by supervisor of physical condition of extract devices/nozzles/enclosures/hoses and extraction unit for damage, change (parts added or removed) and correct operation etc. Check also that daily inspections have been completed. Tick boxes to confirm system ok / change. Add details of any changes. Report changes to Engineering Manager. Record any remedial actions taken.

Week number	Date	System ok	System Change	Details of change / repairs etc	Initial
1					
2					
3					
4					
5					
6					
7					
8					
9					
10					
11					
12					
13					
14					
15					
16					
17					
18					
19					
20					
21					
22					
23					
24					
25					
26					

**Process enclosure, extract offtake, hose/ducting and extract/filtration unit.
Inspection and Maintenance Record**

2. Weekly Inspection

. . . . Continued

Weekly inspection by supervisor of physical condition of extract devices/nozzles/enclosures/hoses and extraction unit for damage, change (parts added or removed) and correct operation etc. Check also that daily inspections have been completed. Tick boxes to confirm system ok / change. Add details of any changes. Report changes to Engineering Manager. Record any remedial actions taken.

Week number	Date	System ok	System Change	Details of change / repairs etc	Initial
27					
28					
29					
30					
31					
32					
33					
34					
35					
36					
37					
38					
39					
40					
41					
42					
43					
44					
45					
46					
47					
48					
49					
50					
51					
52					

**Process enclosure, extract offtake, hose/ducting and extract/filtration unit.
Inspection and Maintenance Record**

3. Monthly Inspection

In addition to weekly checks. Disconnect hoses and check for blockage and smooth operation of fan, signs of dust or vapour / gas / odour carry over. Tick boxes to confirm system ok / change. Add details of any changes. Report changes to Engineering Manager. Record any remedial actions taken.

Month number	Date	System ok	System Change	Details of change / repairs etc	Initial
1					
2					
3					
4					
5					
6					
7					
8					
9					
10					
11					
12					

4. Yearly Inspection

Annual service To include all regular checks together with inspection of filter condition and replacement where necessary, motor and electrical checks,	Comments	Signature of Supervisor : Date:
Annual Thorough Inspection and Testing of LEV System in accordance with C.O.S.H.H. Regulation 9 (max interval 14 months) including reporting.	Comments	Signature of Supervisor : Date: