



A Donaldson Company

A WORLD LEADER IN FUME  
EXTRACTION TECHNOLOGY

# 3D PrintPRO 3

USER MANUAL



## Contents

1	01	Overview of your Extraction system (front)
	02	Overview of your Extraction system (back)
	03	Overview of the Control Panel
	04	Overview of the 3D Printing Setup
2	01	Important safety notes
	02	Safety labels
3	01	Unpacking and unit placement
4	01	Connecting to power supply
5	01	Turning extractor On
6	01	Cleaning the unit
	02	Filter replacement
7	01	Consumable Spares & Filter Disposal
8	01	3D Print Pro 3 Specifications

Overview

1 01



# Overview

1 02

Main Isolation Switch

Mains Inlet

Fuse Compartment

T3.15AH250V

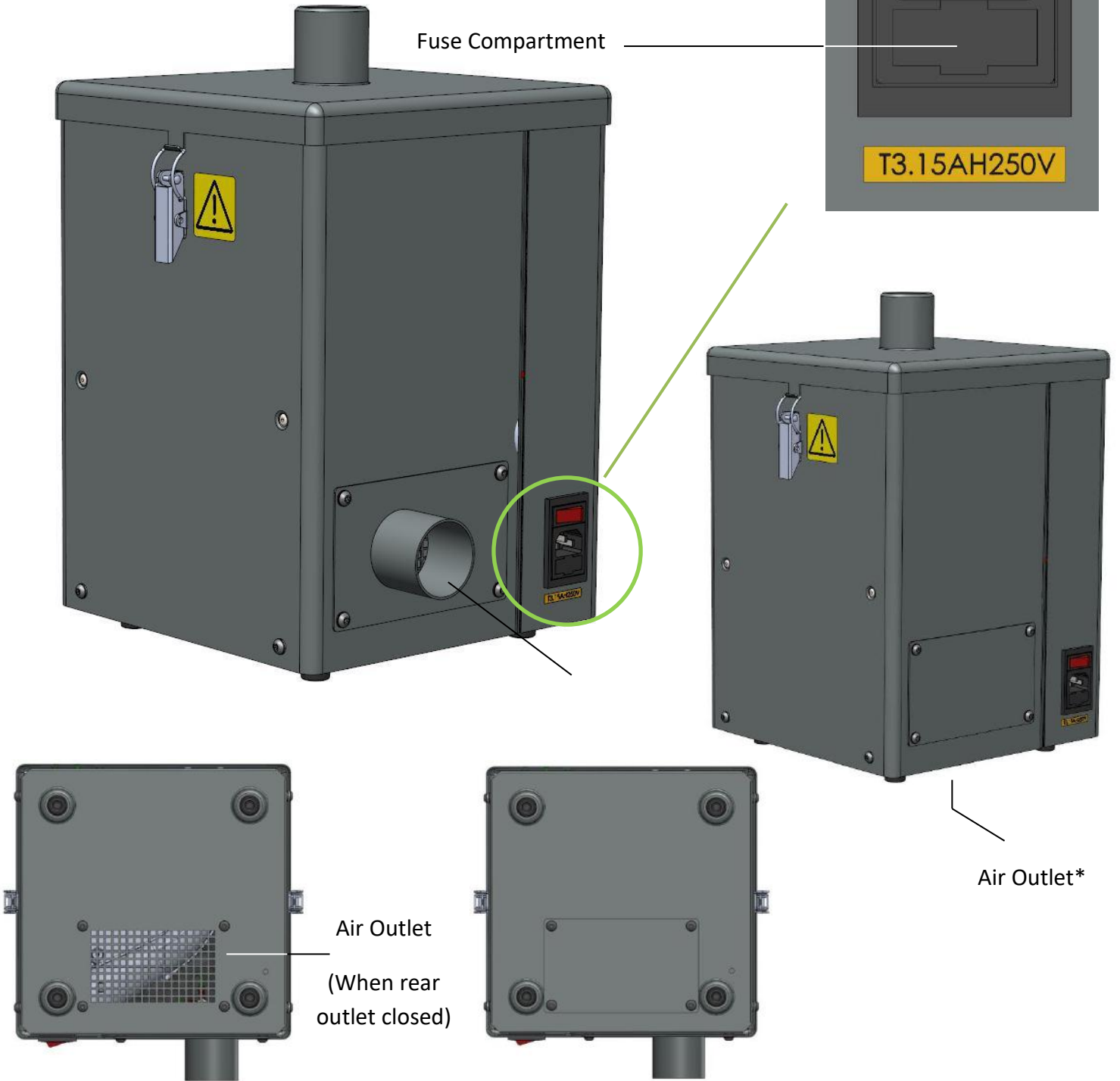

Air Outlet\*

Air Outlet  
(When rear outlet closed)

\*The air outlet can be configured to suit the user's needs. The rear port can be blanked using the plate screwed to the underside of the unit. The air can then exit through the exposed grille under the unit.

Please note that when the rear outlet is being used, the grille located on the bottom of the unit must be blanked off as shown above.

# Overview

1

03

Company Branding

Motor Speed Adjustment

Filter Change Indicator

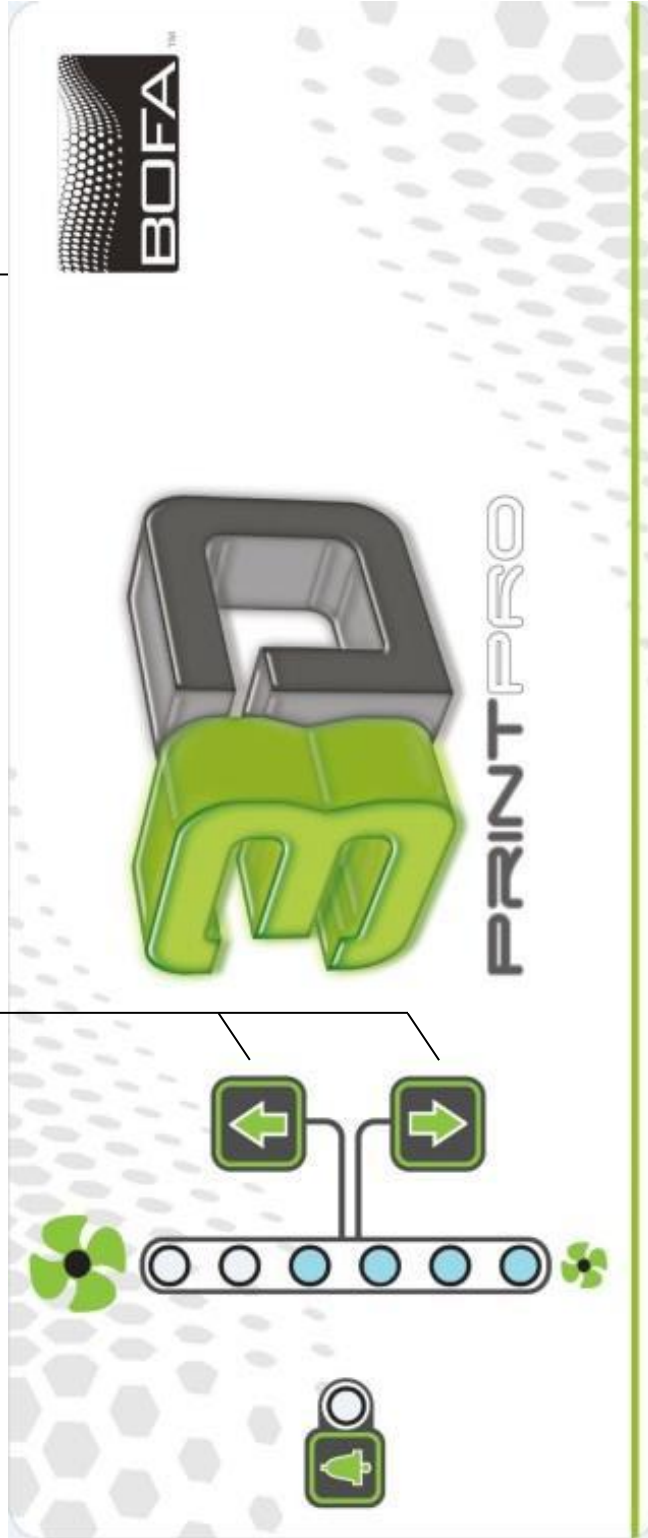

# Overview

1

04

Air Inlet Plenum

3D Printer



3D PrintPRO 3  
Extraction Unit

Air Outlet Plenum

# Safety Instructions



## Important safety notes

Concerning symbols used on the extraction unit and referred to within this manual.



Danger

Refers to an immediately impending danger. If the danger is not avoided, it could result in death or severe (crippling) injury. Please consult the manual when this symbol is displayed.



Warning

Refers to a possibly dangerous situation. If not avoided it could result in death or severe injury. Please consult the manual when this symbol is displayed.



Caution

Refers to a possibly harmful situation. If not avoided, damage could be caused to the product or something in its environment.



Important (Refer to manual)

Refers to handling tip and other particularly useful information. This does not signify a dangerous or harmful situation. Refer to manual when this symbol is displayed.

## Electrical Safety

The 3D Print Pro 3 has been designed to meet the safety requirements of the Low Voltage Directive 2006/95/EC (previously numbered 73/23/EEC)

## Warning

When working with the pump/motor housing open, Live 230/115 volt mains components are accessible. Ensure that the rules and regulations for work on live components are always observed.

## Important

To reduce the risk of fire, electric shock or injury:

1. Always isolate the system from the mains power supply before removing the pump/motor access panel.
2. Use only as described in this manual.
3. Connect the system to a properly grounded outlet.

## Dangers to eyes, breathing and skin

Once used, the filter within the 3D Print Pro system may contain a mixture of particulates, some of which may be sub-micron size. When the used filters are moved it may agitate some of this particulate, which could get into the breathing zone and eyes of the operative. Additionally, depending on the materials being used, the particulate may be an irritant to the skin.

**This unit should not be used on processes with sparks of flammable materials or with explosive dusts and gases, without implementation of additional precautions.**

**Caution: When changing used filters always wear a mask, safety shoes, goggles and gloves.**

## Carbon selection

Please note that the media within the filter fitted in the 3D Print Pro 3 is capable of adsorbing a wide range of organic compounds. However, it is the responsibility of the user to ensure it is suitable for the particular application it is being used on.

## BOFA Technical Service

If problems arises with your 3D Print Pro unit please contact us:

- Visit our website at [www.bofa.co.uk](http://www.bofa.co.uk) for on-line help.
- Or contact the helpline on **+44 (0) 1202 699 444**, Mon-Fri, 9am-5pm.  
Email: [Technical@bofa.co.uk](mailto:Technical@bofa.co.uk)

## Serial Number

For future reference, fill in your system details in the space provided. The serial number is on the rating label located on the side/rear of the unit.

Serial Number:

□	□	/	3	D	-	P	R	I	N	T	P	R	O	3	-	□	□	□	□
---	---	---	---	---	---	---	---	---	---	---	---	---	---	---	---	---	---	---	---

# Safety Instructions



## Warning and Information labels

The following listing details labels used on your 3D Print Pro 3 extraction unit.

## Goggles, Gloves & Mask Label



Location: Front face of filter.

Meaning: Goggles, Gloves and Masks should be worn while handling used filters.

## Do Not Cover Label



Location: Bottom panel.

Meaning: Do not cover any louvers or holes adjacent to the label.

## Electrical Danger



Location: Bottom Panel

Meaning: Removal of panels with this label attached will allow access to potentially live components.

## Warning Label



Location: Next to release clips.

Meaning: Power should be isolated before the panel with this label attached is opened/ removed.

## Serial Number Label



Location: Next to mains inlet.

Meaning: This label contains a variety of information about the extraction unit, including.

- Company name, Address & Contact number
- Extractor model
- Unit serial number
- Operating voltage range
- Maximum current load
- Operating frequency
- Year of Manufacture
- Relevant approval markings/ logos

**PLEASE NOTE:** If the equipment is used in a manner not specified by the manufacturer, the protection provided by the equipment maybe compromised.

## Fire Risk Warning

In the very rare event that a burning ember or spark is drawn into the fume extraction unit, it may be possible that the filters will ignite.

Whilst any resultant fire would typically be retained within the fume extraction unit, the damage to the extractor could be significant. It is therefore essential to minimise the possibility of this occurring by undertaking an appropriate Risk assessment to determine:-

- a). Whether additional fire protection equipment should be installed.
- b). Appropriate maintenance procedures to prevent the risk of build-up of debris which could potentially combust.

This unit should not be used on processes where sparks could occur, with explosive dusts and gases, or with particulates which can be pyrophoric (can spontaneously ignite), without implementation of additional precautions

It is essential that nozzles or other extraction/ fume capture devices and hoses/pipework are cleaned regularly to prevent the build-up of potentially ignitable debris



## Before Installation

### 3 01

#### Packaging Removal & Unit Placement

Before installation, check the extraction unit for damage. All packaging must be removed before the unit is connected to the power supply.

**Please read all instructions in this manual before using this extractor.**

1. Move the unit to the location where it is going to be installed and remove the outer packaging. **This unit should be installed in a well-ventilated area.**

Ensure that 500 mm space is available around any vented panels on the extractor to ensure adequate airflow.

2. Check the filter is located in its correct position before replacing the lid and securing the clips



Do not block or cover the airflow and motor cooling ports on the unit, as this severely restricts airflow and may cause damage to the unit.



Under no circumstances should the exhaust outlet/s be covered as this will restrict the airflow and cause overheating.

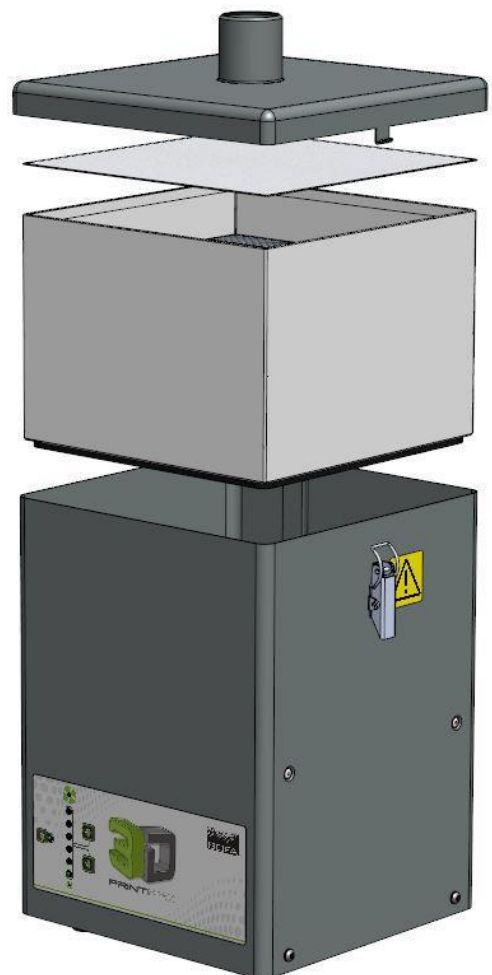

# Installation



## Specification 3D Print Pro 3

Dimensions: Height 413mm Depth 298mm Width 283mm

Weight: 10.5kg

Voltage: 115-230V

Frequency: 50/60Hz

Full load current: 2.0A

Power: 100w

Capacity: 75 m<sup>3</sup>h

### Connection to Power Supply

Please follow the above specification when selecting the power supply outlet for the extraction system, ensure the power supply is suitable before connecting the 3D Print Pro system.

Check the Integrity of the electrical power cable, if the supply cord is damaged the extraction unit should not be connected to the mains. The supply cord should only be replaced by a BOFA engineer as an electrical safety test may be required after replacement.



The extraction unit **MUST** be connected to a properly earthed outlet.



**If your extraction system was ordered with any optional extras please read section 4.03 before the power connection is made as additional connections may be required before power is connected to the extractor.**

Connect the power cable to an isolated electrical supply.

The mains socket should be installed near the extractor it should be easily accessible and able to be switched On/ Off. The cable run should be arranged so as not to create a trip hazard.

## Pairing with the 3D printer System

The 3D PrintPRO 3 has been specially designed to be used alongside a wide spectrum of middle range 3D printers available on the market.

Fume can be captured in a number of ways including nozzles and funnels and BOFA's new 3D plenum range.

The extraction point needs to be as close as possible to the printing area without interfering with the 3D printing process to ensure effective fume extraction.

### 3D Printed Plenum

BOFA offer 'print your own' inlet and outlet plenums to be used as an accessory to your 3D PrintPRO 3. When installed the inlet and outlet plenums extract fume and flood the operators breathing zone with clean filtered air, creating a recirculating extraction system.

The plenums are split into four pieces and can be adjusted in length to suit the printer by simply adding or removing middle sections. The files needed to print the plenums can be found on the BOFA website or are available by request.

See section 1.04 for a detailed look at a typical 3D PrintPRO setup.

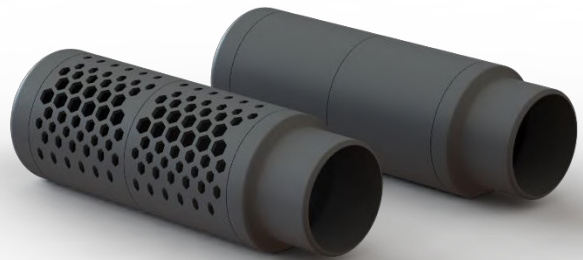

# Operation

## 5 01

### Turning extraction unit On

The 3D Print Pro 3 features a fused IEC inlet for the mains cable as well as a main isolation switch. The unit can be powered on and off by pressing the red rocker switch to the right hand side.

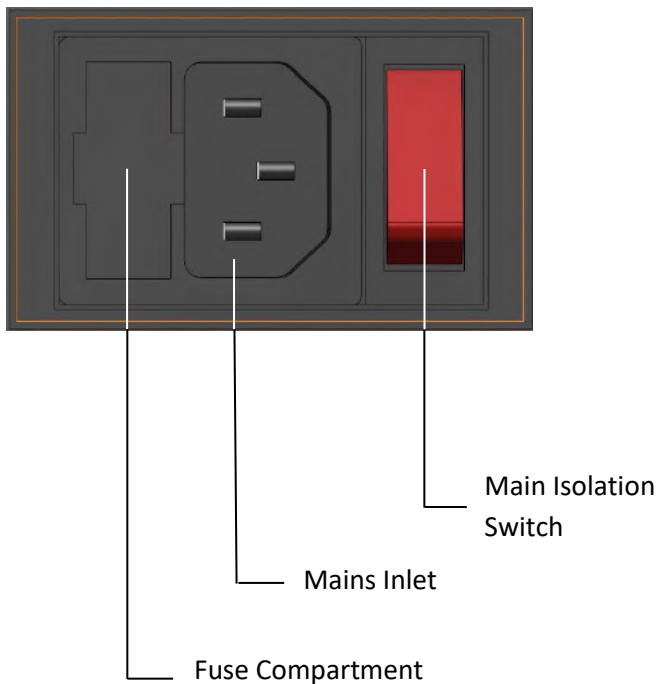

### Setting the desired airflow

The 3D PrintPRO 3 features manual flow control. This enables the user to set the required airflow rate. Over time as the filters begin to block the user should manually increase the motor speed to ensure the correct flow is maintained to compensate for any loss in performance caused by the added restriction of the partially blocked filters.



The extractor and all pipe work must be fully installed and connected before the airflow is set.

### To set the airflow

Press the Up arrow button to increase airflow and press the down arrow button to decrease airflow. The level of airflow is indicated by the vertical row of six blue LEDs to the right of the mains isolation switch. As the airflow increases, more blue LEDs light up and the opposite for decreasing the airflow.

### Increasing the Airflow



### Decreasing the Airflow



# Maintenance



## Maintenance UK

It is a legal requirement, under regulation 9 of the COSHH regulations that all local exhaust ventilation systems are thoroughly examined and tested at least once every 14 months (typically carried out annually). The approved code of practice recommends that a visual check should be carried out at least once a week.

COSHH requires the annual inspection and testing to be carried out by a competent person and specifies that documentation results are recorded in a log.

Contact the seller for more information about inspection and certification.

## Maintenance General

User maintenance is limited to cleaning the unit and filter replacement, only the manufacturers trained maintenance technicians are authorised to carry out component testing and replacement. Unauthorised work or the use of unauthorised replacement filters may result in a potentially dangerous situation and/or damage to the extractor unit and will invalidate the manufacturer's warranty.

## Cleaning the unit

The powder coat finish can be cleaned with a damp cloth and non-aggressive detergent, do not use an abrasive cleaning product as this will damage the finish.

The cooling inlets and outlets should be cleaned once a year to prevent build-up of dust and overheating of the unit.

## Filter Information

A log of filter changes should be maintained by the user. The filters require attention when the display shows the configuration shown on the next page or when the extractor

no longer removes fume efficiently.

It is recommended that a spare set of filters are kept on site to avoid prolonged unit unavailability. Part numbers for replacement filters can be found on the filters fitted in your system.

To prevent overheating, units should not be run with a blocked filter condition, or with dust obstruction of Inlets / Outlets.

## Fire Risk Warning

In the very rare event that a burning ember or spark is drawn into the fume extraction unit, it may be possible that the filters will ignite.

Whilst any resultant fire would typically be retained within the fume extraction unit, the damage to the extractor could be significant.

It is therefore essential to minimise the possibility of this occurring by undertaking an appropriate Risk assessment to determine:-

- a). Whether additional fire protection equipment should be installed.
- b). Appropriate maintenance procedures to prevent the risk of build-up of debris which could potentially combust.

This unit should not be used on processes where sparks could occur, with explosive dusts and gases, or with particulates which can be pyrophoric (can spontaneously ignite), without implementation of additional precautions

It is essential that nozzles or other extraction/ fume capture devices and hoses/pipework are cleaned regularly to prevent the build-up of potentially ignitable debris

# Maintenance

## 6 02

### Filter Replacement

The 3D Print Pro 3 will alert the user when its filters need to be replaced. When the filter becomes full the red alarm LED next to the airflow adjustment buttons will flash.

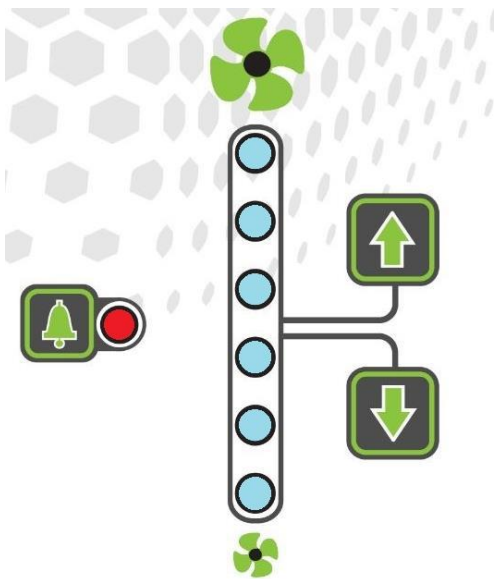

To remove and replace the Pre Filter Pad follow the procedure detailed below.

1. Isolate the electrical supply to the extractor
2. Undo the clips on the sides of the unit and remove the lid.
3. Lift the pre filter pad out from the top of the combined filter and replace with a new pad.
4. Once removed it is recommend that the used filters are bagged and sealed.
5. Replace the lid, and fasten the clips.

**Note: The filter MUST be fitted when the extractor is in use.**

To remove and replace the combined filter follow the procedure detailed below.

1. Isolate the electrical supply to the extractor
2. Undo the clips on the sides of the unit and remove the lid.
3. Lift the filter out of the unit. Once removed it is recommend that the used filters are bagged and sealed.
4. Lower the new filter into position. Replace the lid, and fasten the clips.

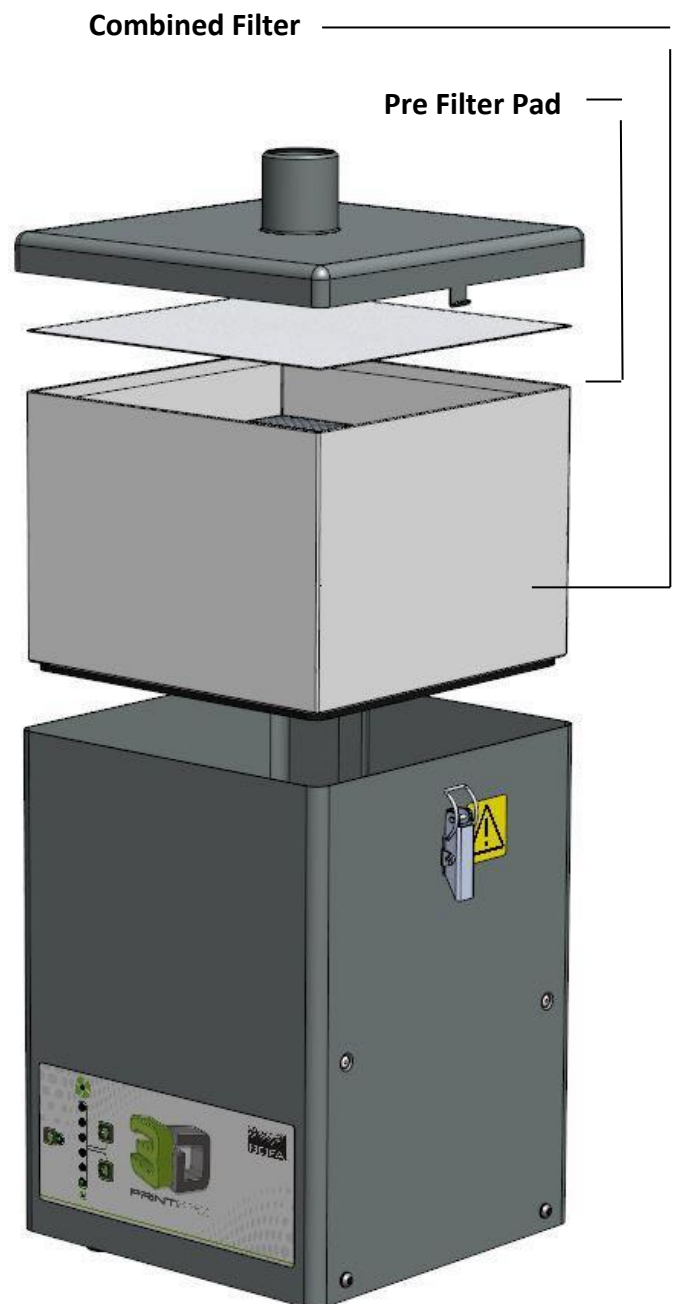

# Replacement Parts



## Consumable Spares

The 3D Print Pro 3 contains a pre filter pad and a combined filter. These should be replaced when instructed to do so by the 3D Print Pro extraction system (see section 6 for replacing the filters)

To maintain performance it is important that the filters are replaced with identical BOFA filters. To re-order please refer to the Filter number printed on the filter installed in your extraction unit.

## Maintenance Protocol

Users can record changes in filter change intervals on the table below.

Unit Serial Number:	
Pre Filter Pad	
Date	Engineer

Combined Filter	
Date	Engineer

## Filter disposal

The combined filter is manufactured from non-toxic materials. Filters are not re-usable, cleaning used filters is not recommended. The method of disposal of the used filters depends on the material deposited on them.

For your guidance

Deposit	EWC Listing*	Comment
Non Hazardous	15 02 03	Can be disposed of as non-hazardous waste.
Hazardous	15 02 02M	The type of hazard needs to be identified and the associated risks defined. The thresholds for these risks can then be compared with the amount of material in the filters to see if they fall into the hazardous category, if so, the filters will need to be disposed of in line with the local/national regulations.

\*European Waste Catalogue

# System Specifications



## Unit: 3D PrintPRO 3

Capacity: 75 m<sup>3</sup>h (44CFM)  
Weight: 10.5kg (23.1 lbs)  
Motor: Centrifugal Fan  
Output: 100w  
Electrical supply: 115-230V  
Hertz: 50/60Hz  
Full Load Current: 2.0A  
Noise Level: Below 57dBA  
(at typical operating speed)

### Size:

	Metric (mm)	Imperial (inches)
Height	413	16.3
Depth	298	11.7
Width	283	11.1

### Filters:

Filter Type	Construction	Efficiency
Pre Filter Pad	Glass Fibre	F7 (96% @ 2 microns)
Combined Filter HEPA	Maxi-pleat Construction with Webbing Spacers	99.997% @ 0.3 microns
Carbon	Granules	Activated

### Environmental operating range:

Temperature: +5°C to + 40°C  
Humidity: Max 80% RH up to 31°C  
Max 50% RH at 40°C

## Contact Information

### **BOFA Headquarters**

19-20 Balena Close  
Creekmoor industrial Estate  
Poole  
Dorset  
BH17 7DU  
UK  
**Phone: +44 (0) 1202 699 444**

### **BOFA Americas**

303 S.Madison Street  
Staunton  
Illinois  
62088  
USA  
**Phone: +1 (618) 205 5007**

### **BOFA International GmbH**

Sudring 62  
D-21465  
Wentorf bei Hamburg  
Germany  
**Phone: +49 (0) 40 7393735-15**